



SERVICE MANUAL

VHF MARINE TRANSCEIVER

IC-M1V

IC-M1EURO V

INTRODUCTION

This service manual describes the latest service information for the IC-M1V/IC-M1EURO V VHF MARINE TRANSCEIVER at the time of publication.

MODEL	VERSION	SYMBOL
IC-M1V	U.S.A.	USA
	S.E.Asia	SEA
IC-M1EURO V	Italy	ITA
	Europe	EUR
	United Kingdom	UK
	Germany	FRG

To upgrade quality, all electrical or mechanical parts and internal circuits are subject to change without notice or obligation.

DANGER

NEVER connect the transceiver to an AC outlet or to a DC power supply that uses more than 10 V. This will ruin the transceiver.

DO NOT expose the transceiver to rain, snow or any liquids.

DO NOT reverse the polarities of the power supply when connecting the transceiver.

DO NOT apply an RF signal of more than 20 dBm (100 mW) to the antenna connector. This could damage the transceiver's front end.

ORDERING PARTS

Be sure to include the following four points when ordering replacement parts:

1. 10-digit order numbers
2. Component part number and name
3. Equipment model name and unit name
4. Quantity required

<SAMPLE ORDER>

1140003830 S.IC TC4W66F IC-M1V MAIN UNIT 1 piece
8930051080 2320 Key board IC-M1EURO V CHASSIS 5 pieces

Addresses are provided on the inside back cover for your convenience.



REPAIR NOTES

1. Make sure a problem is internal before disassembling the transceiver.
2. **DO NOT** open the transceiver until the transceiver is disconnected from its power source.
3. **DO NOT** force any of the variable components. Turn them slowly and smoothly.
4. **DO NOT** short any circuits or electronic parts. An insulated tuning tool **MUST** be used for all adjustments.
5. **DO NOT** keep power ON for a long time when the transceiver is defective.
6. **DO NOT** transmit power into a signal generator or a sweep generator.
7. **ALWAYS** connect a 40 dB or 50 dB attenuator between the transceiver and a deviation meter or spectrum analyzer when using such test equipment.
8. **READ** the instructions of test equipment thoroughly before connecting equipment to the transceiver.

TABLE OF CONTENTS

SECTION 1	SPECIFICATIONS	
	VHF MARINE CHANNEL LIST	1 - 2
SECTION 2	INSIDE VIEWS	
SECTION 3	DISASSEMBLY AND OPTION INSTRUCTIONS	
SECTION 4	CIRCUIT DESCRIPTION	
4 - 1	RECEIVER CIRCUITS	4 - 1
4 - 2	TRANSMITTER CIRCUITS	4 - 2
4 - 3	PLL CIRCUIT	4 - 3
4 - 4	POWER SUPPLY CIRCUITS	4 - 3
4 - 5	CPU PORT ALLOCATIONS	4 - 4
SECTION 5	ADJUSTMENT PROCEDURES	
5 - 1	PREPARATION.....	5 - 1
5 - 2	PLL AND TRANSMITTER ADJUSTMENTS	5 - 3
5 - 3	RECEIVER ADJUSTMENT	5 - 4
5 - 4	TRIMMER ADJUSTMENT	5 - 5
5 - 5	ATIS ADJUSTMENT	5 - 5
SECTION 6	PARTS LIST	
SECTION 7	MECHANICAL PARTS AND DISASSEMBLY	
	AD-95 INFORMATION	7 - 3
SECTION 8	SEMI-CONDUCTOR INFORMATION	
SECTION 9	BOARD LAYOUTS	
9 - 1	CHARGE UNIT (AD-95)	9 - 1
9 - 2	RF AND VR UNITS.....	9 - 2
9 - 3	MAIN UNIT	9 - 4
SECTION 10	BLOCK DIAGRAM	
SECTION 11	VOLTAGE DIAGRAM	
11 - 1	RF UNIT.....	11 - 1
11 - 2	MAIN UNIT	11 - 2

SECTION 1 SPECIFICATIONS

		EIA-152C/204D	EN301-178	
GENERAL	Frequency coverage	Tx: 156.025 MHz–157.425 MHz Rx: 156.025 MHz–163.275 MHz	Tx: 156.025 MHz–157.425 MHz Rx: 156.025 MHz–162.025 MHz	
	Mode	16K0G3E (FM)		
	Power supply requirement	BP-215 (7.4 V DC)		
	Usable temperature	–10 °C to +60 °C (+14°F to +140°F)	–15 °C to +55 °C (+5°F to +131°F)	
	Frequency stability	± 10 ppm	± 1.5 kHz	
	Current drain (with BP-215)	Tx	at 5 W	1.5 A max.
			at 1 W	0.7 A max.
		Rx	at maximum audio	200 mA
			at stand-by	20 mA
	Antenna impedance	Type SMA / 50 Ω		
Dimensions (Projections not included)	52.5(W) × 129(H) × 30(D) mm; 2 ¹ / ₁₆ (W) × 5 ³ / ₃₂ (H) × 1 ³ / ₁₆ (D) inch (with BP-215)			
Weight (with antenna and BP-215)	285 g; 10.1 oz			
TRANSMITTER	RF output power (at 7.4 V DC)	5 W / 1 W / 0.5 W (High / Low / Extra low)		
	Modulation system	Variable reactance frequency modulation		
	Max. frequency deviation	± 5.0 kHz		
	Spurious emissions	65 dB	250 nW	
	Adjacent channel power	60 dB		
	Residual modulation	40 dB		
	Audio harmonic distortion	Less than 10 % at 60 % deviation		
	Microphone impedance	2 kΩ		
RECEIVER	Receive system	Double-conversion super heterodyne		
	Intermediate frequencies	1st: 21.70 MHz, 2nd: 450 kHz		
	Sensitivity	0.35 μV at 12 dB SINAD	0.5 μV at 12 dB SINAD	
	Squelch sensitivity	0.35 μV	0.5 μV	
	Adjacent channel selectivity	70 dB (typical)	70 dB	
	Spurious response	70 dB (typical)	70 dB	
	Intermodulation	70 dB (typical)	68 dB	
	Hum and noise	40 dB		
	Audio output power (at 7.4 V)	350 mW typical at 10 % distortion with an 8 Ω load	200 mW at 10 % distortion with an 8 Ω load	
	Audio frequency response	–3 dB to +1 dB of –6 dB octave from 300 Hz to 3000 Hz		

All stated specifications are subject to change without notice or obligation.

■ VHF MARINE CHANNEL LIST

Channel No.			Frequency (MHz)		Channel No.			Frequency (MHz)		Channel No.			Frequency (MHz)	
USA	INT	CAN	Transmit	Receive	USA	INT	CAN	Transmit	Receive	USA	INT	CAN	Transmit	Receive
	01	01	156.050	160.650	21A		21A	157.050	157.050	73	73	73	156.675	156.675
01A			156.050	156.050		22		157.100	161.700	74	74	74	156.725	156.725
	02	02	156.100	160.700	22A		22A	157.100	157.100	77*1	77	77*1	156.875	156.875
	03	03	156.150	160.750		23	23	157.150	161.750		78		156.925	161.525
03A			156.150	156.150	23A			157.150	157.150	78A		78A	156.925	156.925
	04		156.200	160.800	24	24	24	157.200	161.800		79		156.975	161.575
		04A	156.200	156.200	25	25	25	157.250	161.850	79A		79A	156.975	156.975
	05		156.250	160.850	26	26	26	157.300	161.900		80		157.025	161.625
05A		05A	156.250	156.250	27	27	27	157.350	161.950	80A		80A	157.025	157.025
06	06	06	156.300	156.300	28	28	28	157.400	162.000		81		157.075	161.675
	07		156.350	160.950		60	60	156.025	160.625	81A		81A	157.075	157.075
07A		07A	156.350	156.350		61		156.075	160.675		82		157.125	161.725
08	08	08	156.400	156.400	61A		61A	156.075	156.075	82A		82A	157.125	157.125
09	09	09	156.450	156.450		62		156.125	160.725		83	83	157.175	161.775
10	10	10	156.500	156.500			62A	156.125	156.125	83A		83A	157.175	157.175
11	11	11	156.550	156.550		63		156.175	160.775	84	84	84	157.225	161.825
12	12	12	156.600	156.600	63A			156.175	156.175	84A			157.225	157.225
13*2	13	13*1	156.650	156.650		64	64	156.225	160.825	85	85	85	157.275	161.875
14	14	14	156.700	156.700	64A		64A	156.225	156.225	85A			157.275	157.275
15*2	15*1	15*1	156.750	156.750		65		156.275	160.875	86	86	86	157.325	161.925
16	16	16	156.800	156.800	65A	65A	65A	156.275	156.275	86A			157.325	157.325
17*1	17	17*1	156.850	156.850		66		156.325	160.925	87	87	87	157.375	161.975
	18		156.900	161.500	66A	66A	66A*1	156.325	156.325	87A			157.375	157.375
18A		18A	156.900	156.900	67*2	67	67	156.375	156.375	88	88	88	157.425	162.025
	19		156.950	161.550	68	68	68	156.425	156.425	88A			157.425	157.425
19A		19A	156.950	156.950	69	69	69	156.475	156.475					
20	20	20*1	157.000	161.600	70*3	70*3	70*3	156.525	156.525					
20A			157.000	157.000	71	71	71	156.575	156.575					
	21	21	157.050	161.650	72	72	72	156.625	156.625					

*1 Low power only, *2 Momentary high power, *3 Receive only

NOTE: Channels 3, 21, 23, 61, 64, 81, 82 and 83 **CANNOT** be used by the general public in USA waters.

■ WX CHANNEL LIST ([IC-M1V] only)

Weather channel	Frequency (MHz)		Weather channel	Frequency (MHz)	
	Transmit	Receive		Transmit	Receive
WX01	Receive only	162.550	WX06	Receive only	162.500
WX02	Receive only	162.400	WX07	Receive only	162.525
WX03	Receive only	162.475	WX08	Receive only	161.650
WX04	Receive only	162.425	WX09	Receive only	161.775
WX05	Receive only	162.450	WX10	Receive only	163.275

SECTION 2 INSIDE VIEWS

• MAIN UNIT

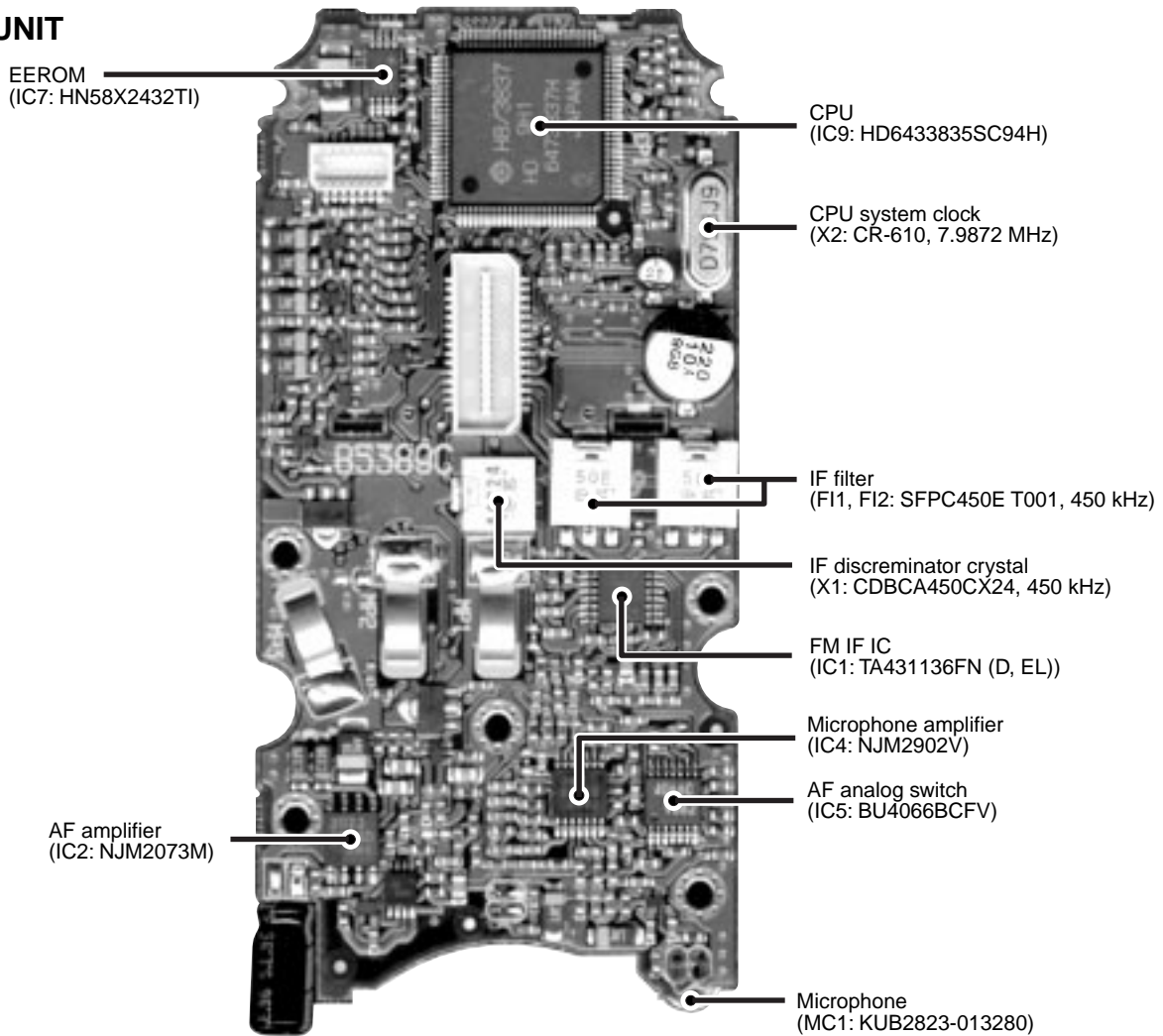

• RF UNIT

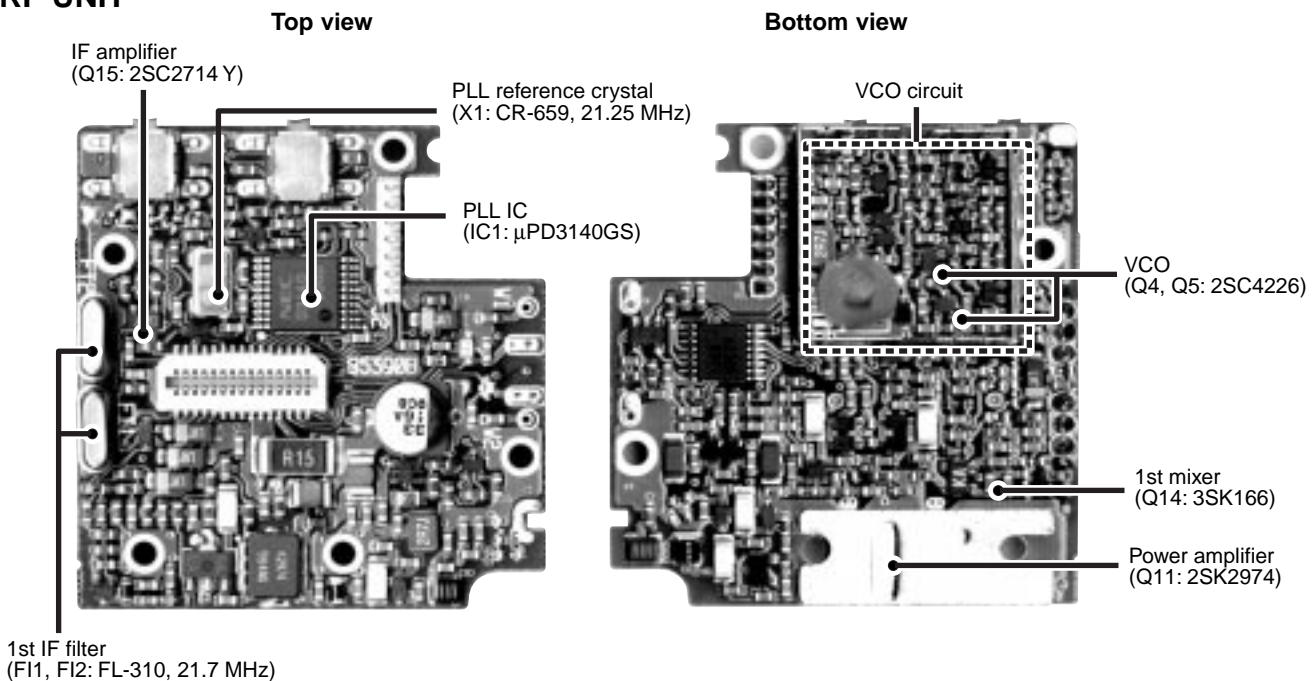

SECTION 3 DISASSEMBLY AND OPTION INSTRUCTIONS

• Removing the Rear panel

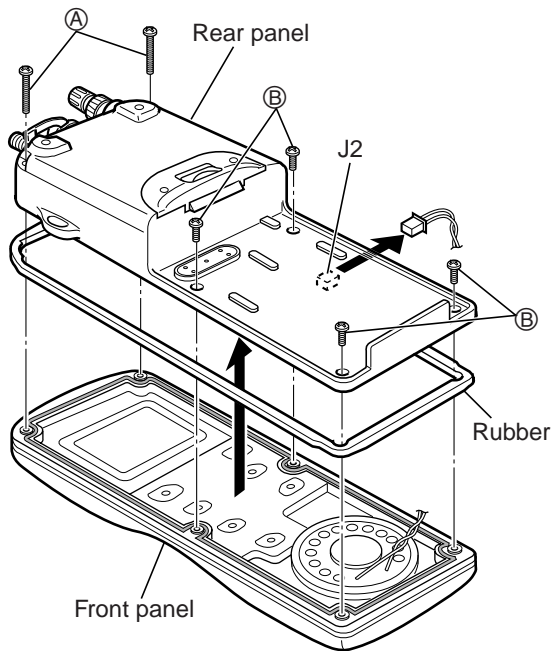

Unscrew 2 screws ① (2 × 20 mm), and 4 screws ② (2 × 5 mm, black) from the rear panel.

NOTE : Once the front panel is removed, grease must be applied to ■ areas before assembly.

Manufacture : Shin-Etsu Chemical
Type : G-501

• Removing the MAIN unit

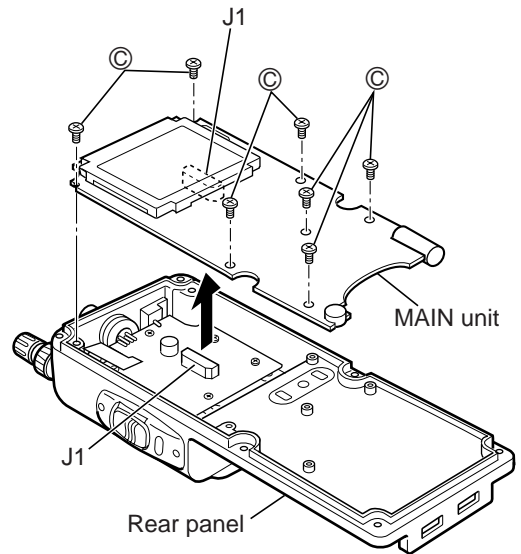

- ① Unscrew 7 screws ③ (2 × 3.5 mm, silver) from the MAIN unit.
- ② Unplug J1 to separate the rear panel and the MAIN unit.

• Removing the RF unit

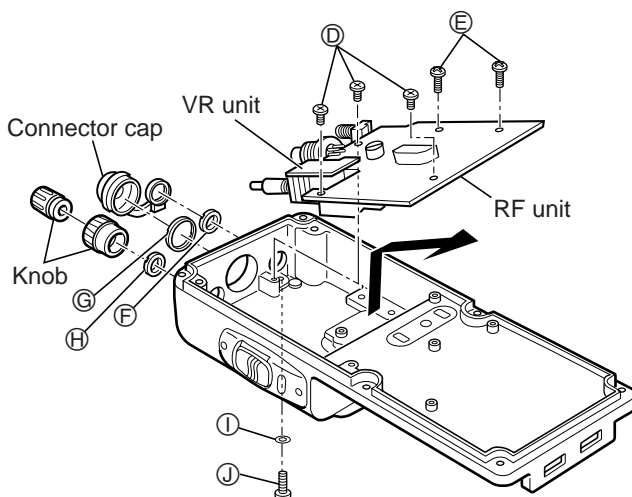

- ① Remove connector cap.
- ② Remove 2 knobs, and unscrew 3 nuts (F, G, H)
- ③ Unscrew 3 screws ④ (2 × 3.5 mm, silver), and 2 screws ⑤ (2 × 5 mm, black) from the RF unit.
- ④ Unscrew 1 screw ⑥ (2 × 5 mm, black), and remove 1 washer ⑦.
- ⑤ Take off the RF unit in the direction of the arrow.

• Install the optional unit (UT-98 or UT-112) to the connector (MAIN unit ; J3)

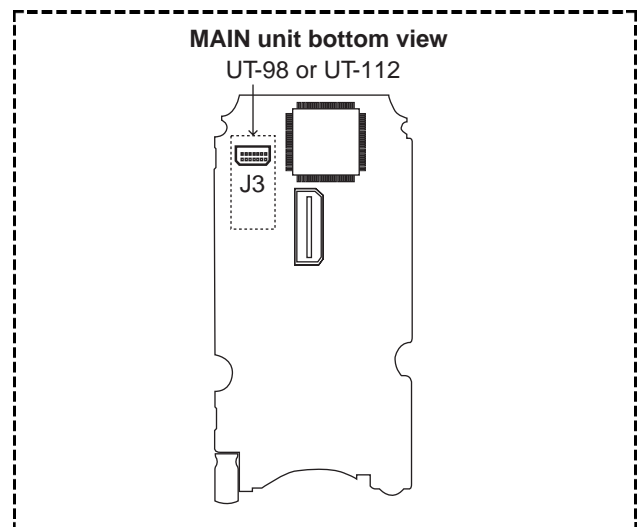

CAUTION :
DO NOT guarantee the waterproof construction when installing the optional unit except distributors or dealers.

SECTION 4 CIRCUIT DESCRIPTION

4-1 RECEIVER CIRCUITS

4-1-1 ANTENNA SWITCHING CIRCUIT (RF UNIT)

The antenna switching circuit functions as a low-pass filter while receiving and as resonator circuit while transmitting. The circuit does not allow transmit signals to enter receiver circuits.

Received signals from the antenna connector pass through the low-pass filter (L15–L17, C72–C77, C79) and antenna switching circuit (D11, D12). The filtered signals are then applied to the RF amplifier circuit (Q13).

4-1-2 RF AND 1ST MIXER CIRCUITS (RF UNIT)

The 1st mixer circuit converts the received signals to a fixed frequency of the 1st IF signal with a PLL output frequency. By changing the PLL frequency, only the desired frequency will be passed through a pair of crystal filters at the next stage of the 1st mixer.

The signals from the antenna switching circuit are passed through the tunable bandpass filter (D13, D14) and amplified at the RF amplifier (Q13). The amplified signals are passed through another tunable bandpass filter (D15–D18), and then applied to the 1st mixer circuit (Q14).

The filtered signals are mixed at the 1st mixer (Q14) with a 1st LO signal coming from the PLL circuit to produce a 21.7 MHz 1st IF signal. The 1st IF signal is passed through a pair of crystal filters (F11, F12) and is then amplified at the IF amplifier (Q15).

4-1-3 2ND IF AND DEMODULATOR CIRCUITS (MAIN AND RF UNITS)

The 2nd mixer circuit converts the 1st IF signal to a 2nd IF signal. A double conversion superheterodyne system (which converts receive signal twice) improves the image rejection and obtain stable receiver gain.

The 1st IF signal is applied to a 2nd mixer section of the FM IF IC (MAIN unit; IC1, pin 16). The signal is then mixed with a 2nd LO signal for conversion into a 450 kHz 2nd IF signal.

IC1 contains the 2nd mixer, limiter amplifier, quadrature detector and active filter circuits. A 21.25 MHz 2nd LO signal is produced at the PLL circuit using the reference frequency.

The 2nd IF signal from the 2nd mixer (MAIN unit; IC1, pin 3) passes through ceramic filters (MAIN unit; F11 and F12) to remove unwanted heterodyned frequencies. It is then amplified at the limiter amplifier section (MAIN unit; IC1, pin 5) and applied to the quadrature detector section (MAIN unit; IC1, pin 10 and 11) to demodulate the 2nd IF signal into AF signals.

4-1-4 AF CIRCUIT (MAIN UNIT)

AF signals from the FM IF IC (IC1, pin 9) are fed to the optional voice scrambler unit to demodulate scrambled audio or are bypassed around the unit via the analog switch (IC5).

The AF signals (detected signals) are passed through the analog switch (IC5, pins 8 and 9) and are then applied to the active low-pass filter (IC4c, pins 9 and 8).

The filtered AF signals are applied to and adjusted audio level at the [VOL] control (VR unit; R1). The level controlled signals are passed through another analog switch (IC3, Q3) which is controlled by "SPSEL" signal from the CPU (IC9, pin 83). The passed signals are applied to the AF power amplifier (IC2), and then output to the internal speaker or [EXT SP] jack.

• 2ND IF AND DEMODULATOR CIRCUITS

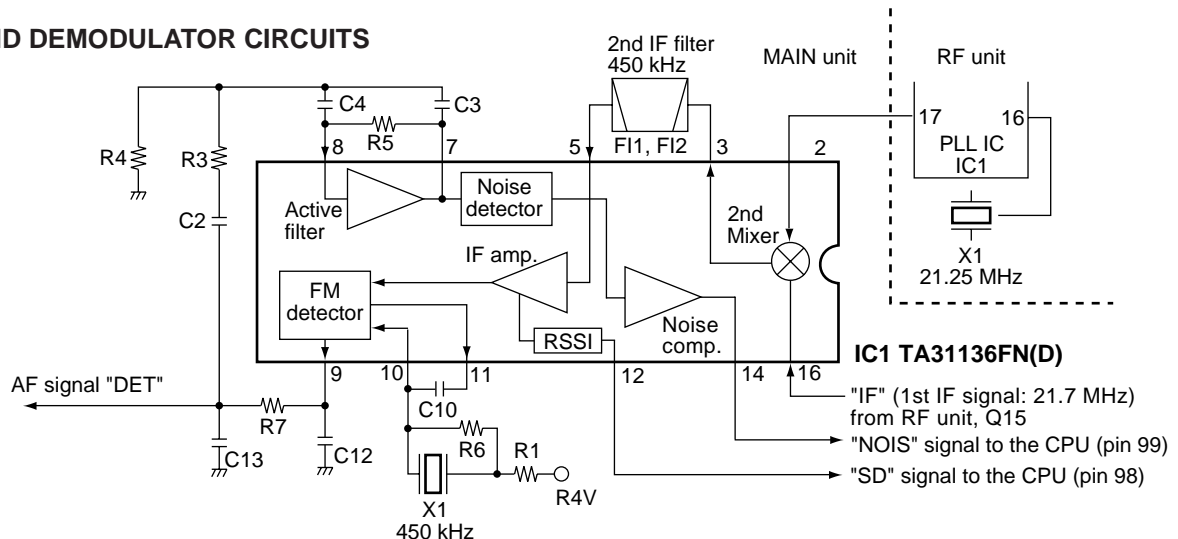

4-1-5 SQUELCH CIRCUIT (MAIN UNIT)

The noise squelch circuit cuts out AF signals when no RF signals are received. By detecting noise components in the AF signals, the squelch circuit switches the AF mute switch.

A portion of the AF signals from the FM IF IC (IC1, pin 9) are applied to the active filter section (IC1, pin 8). The active filter section amplifies and filters noise components. The filtered signals are applied to the noise detector section and output from IC1 (pin 14) as the "NOIS" signal.

The "NOIS" signal from IC1 (pin 14) is applied to the CPU (IC9, pin 99) to analyze the noise condition. The "SQLV" signal from R1 (VR unit) is applied to the CPU (IC9, pin 95) to detect squelch level. The CPU detects the receiving signal strength and cut the AF signal line.

4-2 TRANSMITTER CIRCUITS

4-2-1 MICROPHONE AMPLIFIER CIRCUIT (MAIN UNIT)

The microphone amplifier circuit amplifies audio signals with +6 dB/octave pre-emphasis characteristics from the microphone to a level needed for the modulation circuit.

The AF signals from the microphone are passed through the pre-emphasis circuit (R31, C36) and are then applied to the microphone amplifier (IC4d). The amplified AF signals are applied to the optional voice scrambler unit to scramble the audio via the "MICOUT" signal, or are bypassed around the unit via an analog switch (IC5, pin 4).

The AF signals which bypassed or passed through the voice scrambler unit are amplified again at the limiter-amplifier (IC4a) and then passed through the low-pass filter (IC4b, pins 6 and 7). The filtered audio is applied to the RF unit as the "MOD" signal.

4-2-2 MODULATION CIRCUIT (RF UNIT)

The modulation circuit modulates the VCO oscillating signal (RF signal) using the microphone audio signals.

The audio signals "MOD" change the reactance of D4 to modulate an oscillated signal at the transmitter VCO (Q4, Q5). The oscillated signal is amplified at the buffer-amplifiers (Q6, Q8).

• APC CIRCUIT

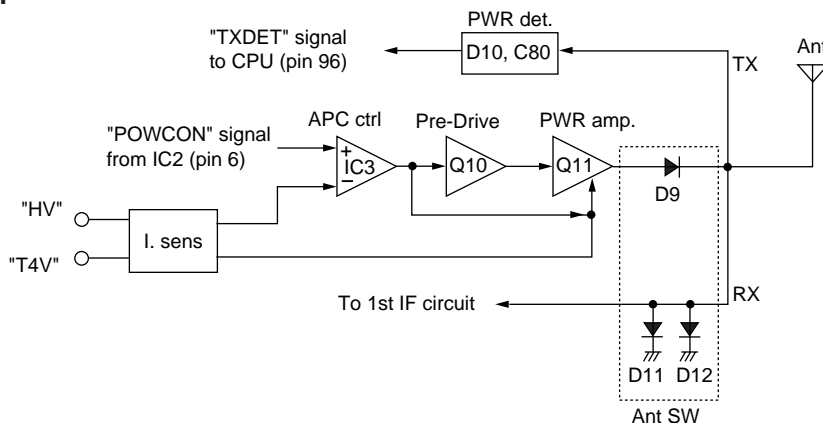

4-2-3 DRIVE/POWER AMPLIFIER CIRCUITS (RF UNIT)

The signal from the VCO circuit passes through the transmit/receive switching circuit (D7, D8) and is applied to the buffer-amplifier (Q9). The amplified signal is amplified by the pre-driver (Q10) and the power amplifier (Q11) to obtain 5 W of RF power (at 7.4 V). The amplified signal passes through the antenna switching circuit (D9), and low-pass filter (L15–L17, C72–C77, C79) and is then applied to the antenna connector.

The bias current of the power amplifier (Q11) is controlled by the APC circuit to stabilize the output power.

4-2-4 APC CIRCUIT (RF AND MAIN UNITS)

The APC circuit provides stable output power from the power amplifier even when the input voltage or temperature changes, and, selects HIGH, LOW or EXTRA LOW output power. The APC circuit consists of an APC sensor and APC control circuits.

• APC SENSOR CIRCUIT (RF UNIT)

The APC sensor circuit (D10, C80, C81, R53, R54) detects the transmit output power level and converts it to DC voltage as an "TXDET" signal. The detected signal is applied to the APC control circuit on the MAIN unit.

• APC CONTROL CIRCUIT (MAIN UNIT)

The "TXDET" signal from the APC sensor circuit is applied to the CPU (IC9, pin 96) to control the input voltage of the pre-driver (RF unit; Q10) and the power amplifier (RF unit; Q11). When the output power changes, the CPU (IC9) outputs "POWCON" signal to the D/A converter (RF unit; IC2). And then "POWCON" signal controls the APC controller (RF unit; IC3) to provide stable output power.

4-3 PLL CIRCUIT (RF UNIT)

A PLL circuit provides stable oscillation of the transmit frequency and receive 1st LO frequency. The PLL output compares the phase of the divided VCO frequency to the reference frequency. The PLL output frequency is controlled by the divided ratio (N-data) of a programmable divider.

The PLL circuit contains a VCO (Q4, Q5, D4, D6). The oscillated signal is amplified at the buffer-amplifiers (Q6, Q7) and then applied to the PLL IC (IC1, pin 2).

The PLL IC contains the prescalers, programmable counter, programmable divider, phase selector and etc. The entered signal is divided at the prescaler and programmable counter sections by the N-data ratio from the CPU. The divided signal is detected on phase at the phase detector using the reference frequency.

If the oscillated signal drifts, the phase of its frequency changes from the reference frequency, causing a lock voltage changes to compensate for the drift in the oscillated frequency.

A portion of the VCO signal is amplified at buffer-amplifiers (Q6, Q8) and is then applied to the receive 1st mixer (Q14) or transmit driver via the TX/RX switching diode (D7, D8).

The lock voltage is also used for the receiver tunable bandpass filter to match the filter's center frequency to the desired receive frequency. The lock voltage is amplified at the buffer-amplifier (Q1) and then applied to the CPU (MAIN unit; IC9, pin 93).

The amplified signal is controlled by the CPU (MAIN unit; IC9), and is then applied to bandpass filters (D13–D18) as "T1", "T2", "T3", "T4" signals via the D/A converter (IC2).

4-4 POWER SUPPLY CIRCUITS VOLTAGE LINES

LINE	DESCRIPTION
HV	The voltage from the attached battery pack.
VCC	The same voltage as the HV line (battery voltage) which is controlled by the power switch ([OFF/VOL] control).
4V	Common 4V converted from the VCC line by the 4V regulator circuit (MAIN unit; Q8–Q10). The output voltage is applied to the D/A converter (RF unit; IC2) and PLL IC (RF unit; IC1), etc.
R4V	Receive 4V converted from the 4V line by the R4 regulator circuit (MAIN unit; Q5). The regulated voltage is applied to the MOD MUTE circuit (RF unit; Q2, D2) and receiver circuit.
T4V	Transmit 4V converted from the 4V line by the T4 regulator circuit (MAIN unit; Q6). The regulated voltage is applied to the transmitter circuit.
S4V	Common 4V converted from the 4V line by the S4V regulator circuit (MAIN unit; Q7). The regulated voltage is applied to the optional scrambler unit, limiter amplifier (MAIN unit; IC4), etc.

• PLL CIRCUIT

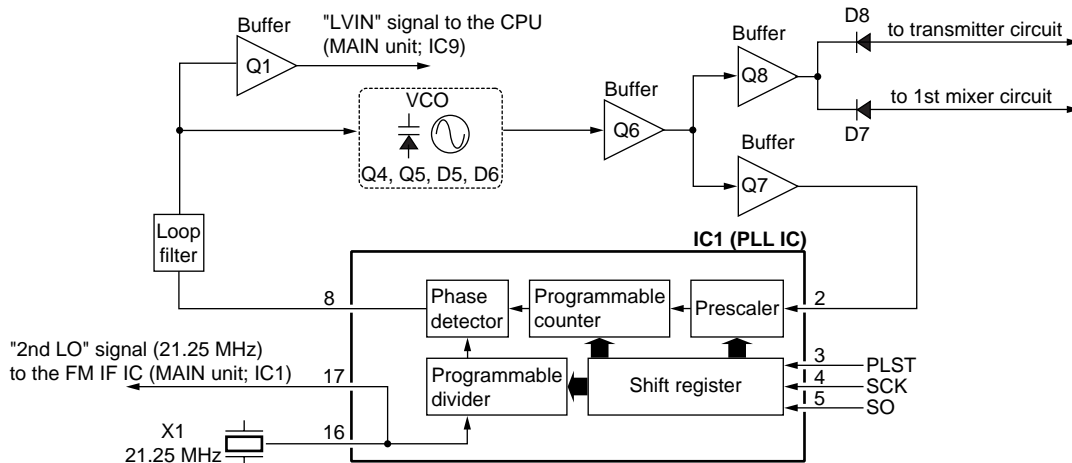

4-5 PORT ALLOCATIONS

4-5-1 CPU (MAIN UNIT; IC9)

Pin number	Port name	Description
1	BATT	Input port for the low battery detection.
11	RM	Outputs the AF mute switch control signal when the voice scrambler is OFF. Low : While squelched.
12	SRM	Outputs the AF mute switch control signal when the voice scrambler is ON. Low : While squelched.
13	SMM	Outputs the MIC mute switch control signal when the voice scrambler is ON. Low : While muted.
14	MM	Outputs the MIC mute switch control signal when the voice scrambler is OFF. Low : While muted.
15	AFON	Outputs control signal for the AF amplifier regulator circuit. High : Activates the AF amplifier circuit (MAIN unit; Q2).
16	OPST	Outputs strobe signals to the optional voice scrambler unit
17	DST	Outputs strobe signals to the D/A converter IC (RF unit; IC2, pin 2).
18	PLST	Outputs strobe signals to the PLL IC (RF unit; IC1, pin 3).
19	SCK	Outputs serial clock.
20	UNLK	Input port for unlock signal. High : PLL is unlocked. Low : PLL is locked.
21	SO	Outputs serial data.
23	OPTIN	Input port for the optional voice scrambler unit connection. Low : The optional voice scrambler unit is connected.
24	MONI	Input port for the [MONI] switch. Low : While [MONI] switch is pushed.
25	16CH	Input port for the [16/9] switch. Low : While [16/9] switch is pushed.
77	LIGHT	Outputs back light control signal. High : Light ON.
78	BEEP	Outputs beep audio signals.
79	4VC	Outputs 4V regulator control signal.
80	R4C	Outputs R4 regulator control signals. Low : While receiving.
81	T4C	Outputs T4 regulator control signals. Low : While transmitting.

Pin number	Port name	Description
82	S4C	Outputs S4 regulator control signals.
83	SPSEL	Outputs speaker select signal Low : The internal speaker is selected.
85	ESDA	Input port for EEPROM serial data. Outputs serial data to the EEPROM.
86	CLIN	Input port for the cloning signal.
87	CLOUT	Outputs the cloning signal.
88	PTT	Input port for the [PTT] switch. High : While [PTT] switch is pushed.
90	MKEY	Input port for [MIC/SP] connector detection.
91	SWA	Input port for the [CH/WX], [UP], [DOWN] switches.
92	SWB	Input port for the [H/L], [DW], [SCN] switches.
93	LVIN	Input port for the PLL lock voltage detection.
94	TEMPS	Input port for the transceiver's internal temperature detection.
95	SQLV	Input port to adjust the squelch level.
96	TXDET	Input port for the TX power detection.
97	TONE	Input port for the WX tone detection.
98	SD	Input port for the receive signal strength detection.
99	NOIS	Input port for noise signals (pulse-type) for squelch operation.
100	BTYPE	Input port for the battery's type detection.

4-5-2 D/A converter IC (RF UNIT; IC2)

Pin number	Port name	Description
5	FRQCON	Output signal to adjust the reference frequency.
6	POWCON	Output signal to adjust TX power.
11, 12, 13	T1-T3	Output tunable bandpass filter control signals.
14	T4	Output tunable bandpass filter control signals while receiving.
	MODCON	Output signal to adjust modulation while transmitting.

SECTION 5 ADJUSTMENT PROCEDURES

5-1 PREPARATION

IC-M1V/M1EURO V can be adjusted by sending adjustment data to the RS-232C port via a PC. When you adjust the IC-M1V/M1EURO V, the optional CS-M1V ADJ ADJUSTMENT SOFTWARE (Rev. 1.0 or later), *OPC-973 CLONING AND ADJUSTMENT CABLE are required.

NOTE: *OPC-973 is a modified optional OPC-973 CLONING AND ADJUSTMENT CABLE (see illustration at CLONING AND ADJUSTMENT CABLE MODIFICATION).

EQUIPMENT	GRADE AND RANGE	EQUIPMENT	GRADE AND RANGE
DC power supply	Output voltage : 7.4 V DC Current capacity : 2 A or more	FM deviation meter	Frequency range : 30–300 MHz Measuring range : 0 to ±10 kHz
RF power meter (terminated type)	Measuring range : 0.1–10 W Frequency range : 100–300 MHz Impedance : 50 Ω SWR : Less than 1.2 : 1	Audio generator	Frequency range : 300–3000 Hz Measuring range : 1–500 mV
Frequency counter	Frequency range : 0.1–300 MHz Frequency accuracy : ±1 ppm or better Sensitivity : 100 mV or better	Standard signal generator (SSG)	Frequency range : 100–300 MHz Output level : 0.1 μV–32 mV (–127 to –17 dBm)
Spectrum analyzer	Frequency range : at least 400 MHz Spectrum bandwidth: ±100 MHz or more	Attenuator	Power attenuation : 40 dB or more Capacity : 10 W or more

■ SYSTEM REQUIREMENTS

- IBM PC compatible computer with an RS -232C serial port (38400 bps or faster).
- Microsoft Windows 95 or Windows 98
- Intel i486DX processor or faster (Pentium 100 MHz or faster recommended)
- At least 16 MB RAM and 10 MB of hard disk space
- 640×480 pixel display (800×600 pixel display recommended)

■ ADJUSTMENT SOFTWARE INSTALLATION

NOTE: Before using the program, make a backup copy of the original disk. After making a backup copy, keep the original disk in a safe place.

- ① Boot up Windows.
- Quit all applications when Windows is running.
- ② Insert the backup disk1 into the appropriate floppy drive.
- ③ Select 'Run' from the [Start] menu.
- ④ Type the setup program name using the full path name, then push the [Enter] key. (A:\ setup)
- ⑤ Follow the prompts.
- ⑥ Program group 'CS-M1V ADJ' appears in the 'Programs' folder of the [Start] menu.

■ STARTING THE PROGRAM

- ① Connect IC-M1V/M1EURO V and PC with the optional cables OPC-478, *OPC-973.
- ② Boot up Windows.
- ③ Click the program group 'CS-M1V ADJ' in the 'Programs' folder of the [Start] menu, then CS-M1V ADJ's window is appeared.
- ④ Click 'Connect' on the CS-M1V's window, then appears IC-M1V's/M1EURO V's up-to-date condition.
- ⑤ Set or modify adjustment data as desired. See illustration at ADJUSTMENT SOFTWARE'S SCREEN DISPLAY EXAMPLE on page 5-2.

IBM is a registered trademark of International Bussiness Machines Corporation in the U.S.A. and other countries. Microsoft and Windows are registered trademarks of Microsoft Corporation in U.S.A. and other countries. Screen shots produced with permission from Microsoft Corporation. All other products or brands are registered trademarks or trademarks of their respective holders.

• CLONING AND ADJUSTMENT CABLE MODIFICATION

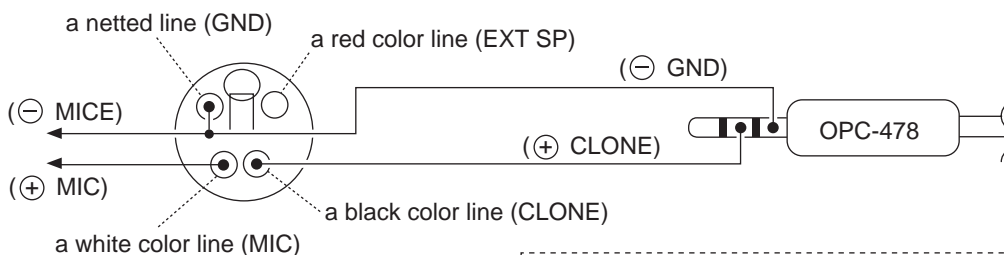

INFORMATION: When ordering OPC-973

Part Name: OPC-973
Order Number: 8900009890

• ADJUSTMENT SPFTWARE'S SCREEN DISPLAY EXAMPLE

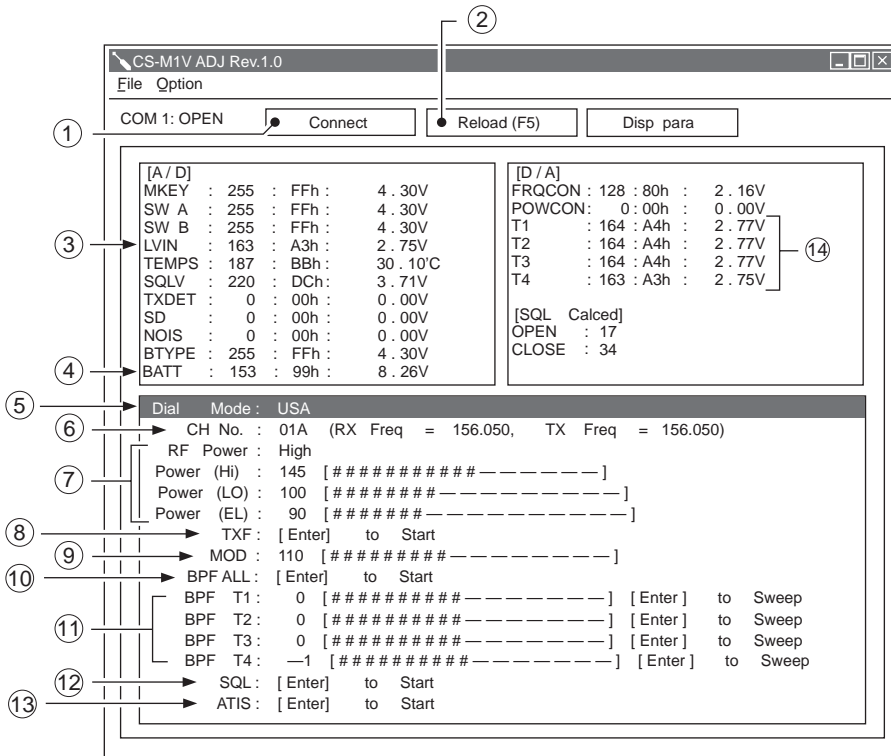

- ①: Connect IC-M1V/M1EURO V with PC via an RS-232C serial cable
- ②: Renew adjustment data
- ③: PLL lock voltage measurement
- ④: Connected DC voltage measurement
- ⑤: Version select
- ⑥: Operating channel select
- ⑦: RF output power adjustments
- ⑧: Reference frequency adjustment
- ⑨: FM deviation adjustment
- ⑩: Receive sensitivity adjustment (automatically)
- ⑪: Receive sensitivity adjustments (manually)
- ⑫: Squelch level adjustment
- ⑬: ATIS adjustment ([FRG] only)
- ⑭: Receive sensitivity measurement

NOTE: The above values for settings are example only. Each transceiver has its own specific values for each setting.

• CONNECTION

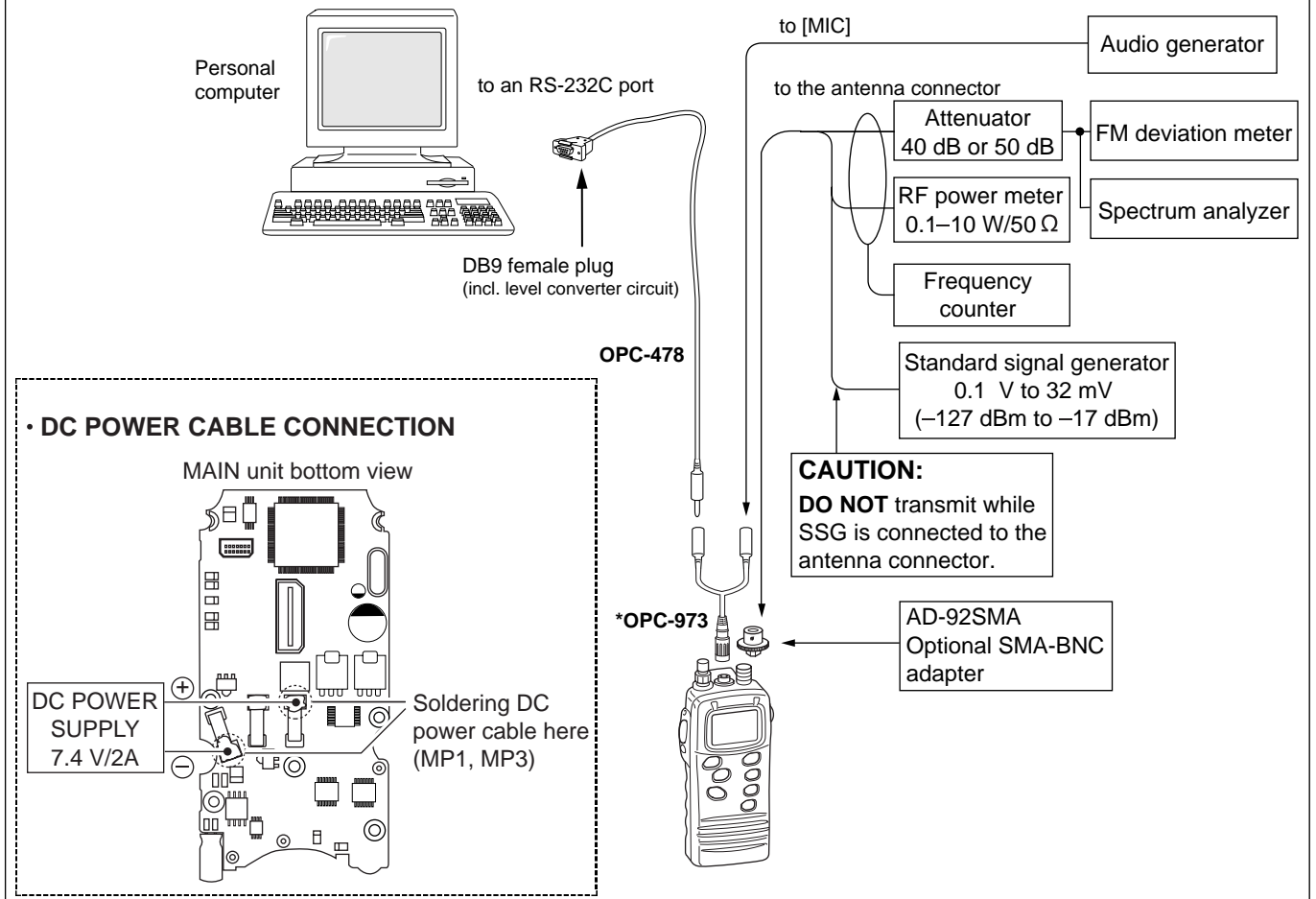

5-2 PLL AND TRANSMITTER ADJUSTMENTS

Select an operation using [↑] / [↓] keys, then set specified value using [←] / [→] keys on the connected computer keyboard.

ADJUSTMENT	ADJUSTMENT CONDITION	MEASUREMENT		VALUE
		UNIT	LOCATION	
PLL LOCK VOLTAGE	1 <ul style="list-style-type: none"> • Operating channel : ch 16 • Receiving 		Use the adjustment program. (see page 5-2)	2.3–3.3 V Verify on the computer display (LVIN)
	2 <ul style="list-style-type: none"> • Operating channel : ch 16 • Connect the RF power meter or 50 Ω dummy load to the antenna connector. • Transmitting 			
REFERENCE FREQUENCY	1 <ul style="list-style-type: none"> • Operating channel : ch 16 • Connect the RF power meter or 50 Ω dummy load to the antenna connector. • Transmitting 	Top panel	Loosely couple the frequency counter to the antenna connector.	156.800000 MHz
OUTPUT POWER	1 <ul style="list-style-type: none"> • Operating channel : ch 16 • [H/L] switch : High • Transmitting 	Top panel	Connect the RF power meter to the antenna connector.	5.0 W (except [FRG]) 1.0 W ([FRG] only)
	2 <ul style="list-style-type: none"> • [H/L] switch : Low • Transmitting 			1.0 W (except [FRG]) 0.5 W ([FRG] only)
	3 <ul style="list-style-type: none"> • [H/L] switch : Extra low • Transmitting 			0.5 W (except [FRG])
FM DEVIATION	1 <ul style="list-style-type: none"> • Operating channel : ch 16 • [H/L] switch : High • Connect the audio generator to the [MIC] jack and set as: 1.0 kHz/40 mV rms. • Set the FM deviation meter as: HPF : OFF LPF : 20 kHz De-emphasis : OFF Detector : (P–P)/2 • Transmitting 	Top panel	Connect the FM deviation meter to the antenna connector through the attenuator.	±4.3 kHz

5-3 RECEIVER ADJUSTMENT

Select an operation using [↑] / [↓] keys, then set specified value using [←] / [→] keys on the connected computer keyboard.

ADJUSTMENT	ADJUSTMENT CONDITION	VALUE
RX SENSITIVITY	1 <ul style="list-style-type: none"> • Operating channel : ch 16 • Connect a standard signal generator to the antenna connector and set as: <ul style="list-style-type: none"> Frequency : 156.800 MHz Level : 3.2 μV* (-97 dBm) [IC-M1V] <li style="padding-left: 20px;">: 4.5 μV* (-94 dBm) [IC-M1EURO V] Modulation : 1 kHz Deviation : \pm3.5 kHz • Receiving 	Maxmun level on the computer display (T1–T4) respectively.
	<p>CONVENIENT: The BPF T1–BPF T4 can be adjusted automatically.</p> <p>①-1: Set the cursor to “BPF ALL” on the adjustment program and then push [ENTER] key.</p> <p>①-2: The connected PC tunes BPF T1–BPF T4 to peak levels.</p> <p style="text-align: center;">or</p> <p>②-1: Set the cursor to one of BPF T1, T2, T3, or T4 as desired.</p> <p>②-2: Push [ENTER] key to start tuning.</p> <p>②-3: Repeat ②-1 and ②-2 to perform additional BPF tuning.</p>	
SQUELCH LEVEL	1 <ul style="list-style-type: none"> • Operating channel : ch 16 • No RF signals are applied to the antenna connector. • Receiving • Set the cursor to “SQL” on the adjustment program and push [ENTER] key, then push [ENTER] key again. 	<p>NOTE: Squelch level adjustment is adjusted automatically by the adjustment program.</p>
	2 <ul style="list-style-type: none"> • Operating channel : ch 16 • Connect a standard signal generator to the antenna connector and set as : <ul style="list-style-type: none"> Level : 0.71 μV* (-110 dBm) [IC-M1V] <li style="padding-left: 20px;">: 1 μV* (-107 dBm) [IC-M1EURO V] Modulation : 1 kHz Deviation : \pm3.5 kHz • Receiving • Push [ENTER] key on the keyboard. 	

*The output level of the standard signal generator (SSG) is indicated as the SSG's open circuit.

5-4 TRIMMER ADJUSTMENT

ADJUSTMENT	ADJUSTMENT CONDITION	MEASUREMENT		VALUE	ADJUSTMENT POINT	
		UNIT	LOCATION		UNIT	ADJUST
TX SPURIOUS ([M1EURO V] only)	1 <ul style="list-style-type: none"> • Operating channel : ch 16 • [H/L] switch : High • No signal apply to the [MIC] jack. • Transmitting 	Top panel	Connect the spectrum analyzer to the antenna connector through the attenuator.	High-harmonics components are minimum value.	RF	L15

5-5 ATIS ADJUSTMENT

Select an operation using [↑] / [↓] keys, then set specified value using [←] / [→] keys on the connected computer keyboard.

ADJUSTMENT	ADJUSTMENT CONDITION	MEASUREMENT		VALUE
		UNIT	LOCATION	
ATIS MODULATION ([FRG] only)	1 <ul style="list-style-type: none"> • Operating channel : ch 16 • [H/L] switch : High • Connect the audio generator to the [MIC] jack and set as: 1.0 kHz/40 mV rms. • Set the FM deviation meter as: HPF : OFF LPF : 20 kHz De-emphasis : OFF Detector : (P-P)/2 • Set the cursor to "ATIS" on the adjustment program and push [ENTER] key. • Transmitting 	Top panel	Connect the FM deviation meter to the antenna connector through the attenuator.	±1.3 kHz (1300 Hz)
	2 <ul style="list-style-type: none"> • Set the cursor to "ATIS" on the adjustment program and push [ENTER] key. • Transmitting 			±2.1 kHz (2100 Hz)

• IC-M1EURO V RF UNIT TOP VIEW

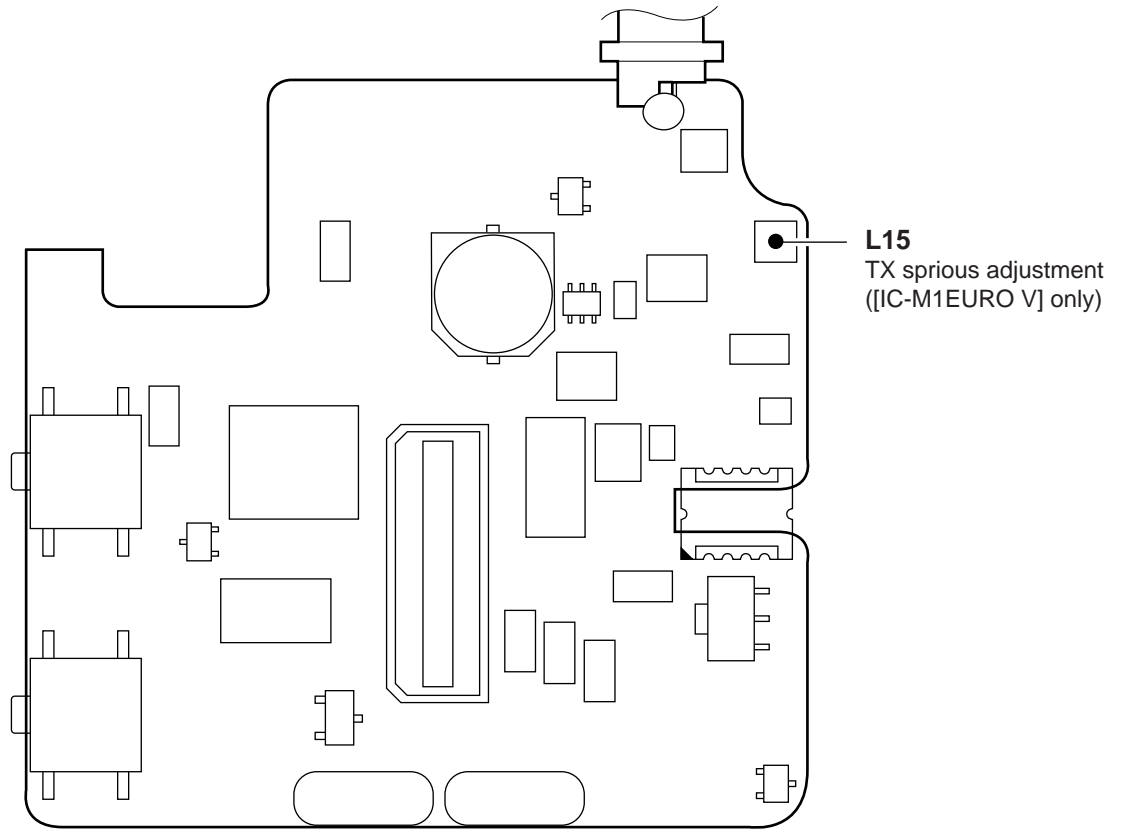

SECTION 6 PARTS LIST

[MAIN UNIT]

REF NO.	ORDER NO.	DESCRIPTION	
IC1	1110003490	S.IC	TA31136FN (D,EL)
IC2	1110002420	S.IC	NJM2073M-T1
IC3	1130007300	S.IC	TC4W66FU (TE12L)
IC4	1110003780	S.IC	NJM2902V-TE1
IC5	1130008090	S.IC	BU4066BCFV-E1
IC6	1180001990	S.IC	XC62FP4302MR
IC7	1130009680	S.IC	HN58X2432TI
IC8	1130009110	S.IC	S-80942ANMP-DD6-T2
IC9	1140008950	S.IC	HD6433835SD05H
Q1	1520000460	S.TRANSISTOR	2SB1132 T100 R
Q2	1590001190	S.TRANSISTOR	XP6501-(TX) .AB
Q3	1590000430	S.TRANSISTOR	DTC144EUA T106
Q4	1590002530	S.TRANSISTOR	UN911H (TX)
Q5	1510000670	S.TRANSISTOR	2SA1588-GR (TE85R)
Q6	1510000670	S.TRANSISTOR	2SA1588-GR (TE85R)
Q7	1510000670	S.TRANSISTOR	2SA1588-GR (TE85R)
Q8	1590000430	S.TRANSISTOR	DTC144EUA T106
Q9	1590001190	S.TRANSISTOR	XP6501-(TX) .AB
Q10	1520000460	S.TRANSISTOR	2SB1132 T100 R
Q11	1590000660	S.TRANSISTOR	DTC144TU T107
Q12	1530000160	S.TRANSISTOR	2SC2712-Y (TE85RTEM)
Q13	1530000160	S.TRANSISTOR	2SC2712-Y (TE85RTEM)
Q14	1530000160	S.TRANSISTOR	2SC2712-Y (TE85RTEM)
Q15	1530000160	S.TRANSISTOR	2SC2712-Y (TE85RTEM)
Q16	1590001920	S.TRANSISTOR	UN911F (TX)
D1	1750000130	S.DIODE	DA204U T107
FI1	2020001490	S.CERAMIC	SFPC450E-TC01
FI2	2020001490	S.CERAMIC	SFPC450E-TC01
X1	6070000210	S.DISCRIMINATOR	CDBCA450CX24
X2	6050010290	S.XTAL	CR-610 (7.9872 MHz)
R1	7030003390	S.RESISTOR	ERJ3GEYJ 391 V (390 Ω)
R2	7030003460	S.RESISTOR	ERJ3GEYJ 152 V (1.5 kΩ)
R3	7030003700	S.RESISTOR	ERJ3GEYJ 154 V (150 kΩ)
R4	7030003540	S.RESISTOR	ERJ3GEYJ 682 V (6.8 kΩ)
R5	7030003720	S.RESISTOR	ERJ3GEYJ 224 V (220 kΩ)
R6	7030003450	S.RESISTOR	ERJ3GEYJ 122 V (1.2 kΩ)
R7	7030003400	S.RESISTOR	ERJ3GEYJ 471 V (470 Ω)
R8	7030003610	S.RESISTOR	ERJ3GEYJ 273 V (27 kΩ)
R9	7030003800	S.RESISTOR	ERJ3GEYJ 105 V (1 MΩ)
R10	7030003440	S.RESISTOR	ERJ3GEYJ 102 V (1 kΩ)
R11	7030003480	S.RESISTOR	ERJ3GEYJ 222 V (2.2 kΩ)
R12	7030003500	S.RESISTOR	ERJ3GEYJ 332 V (3.3 kΩ)
R13	7030003200	S.RESISTOR	ERJ3GEYJ 100 V (10 Ω)
R14	7030003200	S.RESISTOR	ERJ3GEYJ 100 V (10 Ω)
R17	7030003560	S.RESISTOR	ERJ3GEYJ 103 V (10 kΩ)
R18	7030003560	S.RESISTOR	ERJ3GEYJ 103 V (10 kΩ)
R19	7030003570	S.RESISTOR	ERJ3GEYJ 123 V (12 kΩ)
R20	7030003800	S.RESISTOR	ERJ3GEYJ 105 V (1 MΩ)
R21	7030003720	S.RESISTOR	ERJ3GEYJ 224 V (220 kΩ)
R23	7030003680	S.RESISTOR	ERJ3GEYJ 104 V (100 kΩ)
R24	7030003680	S.RESISTOR	ERJ3GEYJ 104 V (100 kΩ)
R25	7030003680	S.RESISTOR	ERJ3GEYJ 104 V (100 kΩ)
R26	7030003680	S.RESISTOR	ERJ3GEYJ 104 V (100 kΩ)
R27	7030003620	S.RESISTOR	ERJ3GEYJ 333 V (33 kΩ)
R28	7030003400	S.RESISTOR	ERJ3GEYJ 471 V (470 Ω)
R29	7030003680	S.RESISTOR	ERJ3GEYJ 104 V (100 kΩ)
R30	7030003790	S.RESISTOR	ERJ3GEYJ 824 V (820 kΩ)
R31	7030003600	S.RESISTOR	ERJ3GEYJ 223 V (22 kΩ)
R32	7030003760	S.RESISTOR	ERJ3GEYJ 474 V (470 kΩ)
R33	7030003600	S.RESISTOR	ERJ3GEYJ 223 V (22 kΩ)
R34	7030003680	S.RESISTOR	ERJ3GEYJ 104 V (100 kΩ)
R35	7030003760	S.RESISTOR	ERJ3GEYJ 474 V (470 kΩ)
R36	7030003680	S.RESISTOR	ERJ3GEYJ 104 V (100 kΩ)
R37	7030003680	S.RESISTOR	ERJ3GEYJ 104 V (100 kΩ)
R38	7030003680	S.RESISTOR	ERJ3GEYJ 104 V (100 kΩ)
R39	7030003680	S.RESISTOR	ERJ3GEYJ 104 V (100 kΩ)

[MAIN UNIT]

REF NO.	ORDER NO.	DESCRIPTION	
R40	7030003680	S.RESISTOR	ERJ3GEYJ 104 V (100 kΩ)
R41	7030003680	S.RESISTOR	ERJ3GEYJ 104 V (100 kΩ)
R42	7030003580	S.RESISTOR	ERJ3GEYJ 153 V (15 kΩ)
R43	7030003800	S.RESISTOR	ERJ3GEYJ 105 V (1 MΩ)
R44	7030003680	S.RESISTOR	ERJ3GEYJ 104 V (100 kΩ)
R45	7030003480	S.RESISTOR	ERJ3GEYJ 222 V (2.2 kΩ)
R46	7030003720	S.RESISTOR	ERJ3GEYJ 224 V (220 kΩ)
R48	7030003610	S.RESISTOR	ERJ3GEYJ 273 V (27 kΩ)
R49	7030003690	S.RESISTOR	ERJ3GEYJ 124 V (120 kΩ)
R50	7030003600	S.RESISTOR	ERJ3GEYJ 223 V (22 kΩ)
R51	7030003690	S.RESISTOR	ERJ3GEYJ 124 V (120 kΩ)
R52	7030003680	S.RESISTOR	ERJ3GEYJ 104 V (100 kΩ)
R53	7030003440	S.RESISTOR	ERJ3GEYJ 102 V (1 kΩ)
R54	7030003460	S.RESISTOR	ERJ3GEYJ 152 V (1.5 kΩ)
R55	7030003750	S.RESISTOR	ERJ3GEYJ 394 V (390 kΩ)
R56	7030003560	S.RESISTOR	ERJ3GEYJ 103 V (10 kΩ)
R57	7030003710	S.RESISTOR	ERJ3GEYJ 184 V (180 kΩ)
R58	7030003650	S.RESISTOR	ERJ3GEYJ 563 V (56 kΩ)
R59	7030003600	S.RESISTOR	ERJ3GEYJ 223 V (22 kΩ)
R60	7030003690	S.RESISTOR	ERJ3GEYJ 124 V (120 kΩ)
R61	7030003680	S.RESISTOR	ERJ3GEYJ 104 V (100 kΩ)
R62	7030003440	S.RESISTOR	ERJ3GEYJ 102 V (1 kΩ)
R63	7030003460	S.RESISTOR	ERJ3GEYJ 152 V (1.5 kΩ)
R64	7030003600	S.RESISTOR	ERJ3GEYJ 223 V (22 kΩ)
R65	7030003510	S.RESISTOR	ERJ3GEYJ 392 V (3.9 kΩ)
R66	7030003470	S.RESISTOR	ERJ3GEYJ 182 V (1.8 kΩ)
R67	7030003280	S.RESISTOR	ERJ3GEYJ 470 V (47 Ω)
R68	7030003520	S.RESISTOR	ERJ3GEYJ 472 V (4.7 kΩ)
R69	7030003520	S.RESISTOR	ERJ3GEYJ 472 V (4.7 kΩ)
R70	7030003520	S.RESISTOR	ERJ3GEYJ 472 V (4.7 kΩ)
R71	7030003480	S.RESISTOR	ERJ3GEYJ 222 V (2.2 kΩ)
R72	7030003600	S.RESISTOR	ERJ3GEYJ 223 V (22 kΩ)
R73	7030003560	S.RESISTOR	ERJ3GEYJ 103 V (10 kΩ)
R74	7030005520	S.RESISTOR	RR0816R-334-D (330 kΩ)
R75	7030005630	S.RESISTOR	RR0816R-154-D (150 kΩ)
R76	7030003760	S.RESISTOR	ERJ3GEYJ 474 V (470 kΩ)
R77	7030003580	S.RESISTOR	ERJ3GEYJ 153 V (15 kΩ)
R78	7030003440	S.RESISTOR	ERJ3GEYJ 102 V (1 kΩ)
R79	7030003440	S.RESISTOR	ERJ3GEYJ 102 V (1 kΩ)
R81	7030004120	S.RESISTOR	ERJ3GEYJ 203 V (20 kΩ)
R82	7030003560	S.RESISTOR	ERJ3GEYJ 103 V (10 kΩ)
R83	7030004120	S.RESISTOR	ERJ3GEYJ 203 V (20 kΩ)
R84	7030003560	S.RESISTOR	ERJ3GEYJ 103 V (10 kΩ)
R85	7030004120	S.RESISTOR	ERJ3GEYJ 203 V (20 kΩ)
R86	7030003560	S.RESISTOR	ERJ3GEYJ 103 V (10 kΩ)
R87	7030004120	S.RESISTOR	ERJ3GEYJ 203 V (20 kΩ)
R88	7030003560	S.RESISTOR	ERJ3GEYJ 103 V (10 kΩ)
R89	7030004120	S.RESISTOR	ERJ3GEYJ 203 V (20 kΩ)
R90	7030003560	S.RESISTOR	ERJ3GEYJ 103 V (10 kΩ)
R91	7030004120	S.RESISTOR	ERJ3GEYJ 203 V (20 kΩ)
R92	7030003560	S.RESISTOR	ERJ3GEYJ 103 V (10 kΩ)
R93	7030004120	S.RESISTOR	ERJ3GEYJ 203 V (20 kΩ)
R94	7030003560	S.RESISTOR	ERJ3GEYJ 103 V (10 kΩ)
R95	7030004120	S.RESISTOR	ERJ3GEYJ 203 V (20 kΩ)
R96	7030004120	S.RESISTOR	ERJ3GEYJ 203 V (20 kΩ)
R97	7030003440	S.RESISTOR	ERJ3GEYJ 102 V (1 kΩ)
R98	7030003760	S.RESISTOR	ERJ3GEYJ 474 V (470 kΩ)
R99	7030003560	S.RESISTOR	ERJ3GEYJ 103 V (10 kΩ)
R100	7030003560	S.RESISTOR	ERJ3GEYJ 103 V (10 kΩ)
R101	7030003560	S.RESISTOR	ERJ3GEYJ 103 V (10 kΩ)
R102	7030003800	S.RESISTOR	ERJ3GEYJ 105 V (1 MΩ)
R103	7030003680	S.RESISTOR	ERJ3GEYJ 104 V (100 kΩ)
R104	7030003680	S.RESISTOR	ERJ3GEYJ 104 V (100 kΩ)
R105	7030003680	S.RESISTOR	ERJ3GEYJ 104 V (100 kΩ)
R106	7030003680	S.RESISTOR	ERJ3GEYJ 104 V (100 kΩ)
R107	7030003440	S.RESISTOR	ERJ3GEYJ 102 V (1 kΩ)
R108	7030003440	S.RESISTOR	ERJ3GEYJ 102 V (1 kΩ)
R109	7030003440	S.RESISTOR	ERJ3GEYJ 102 V (1 kΩ)
R110	7030003440	S.RESISTOR	ERJ3GEYJ 102 V (1 kΩ)
R111	7030003440	S.RESISTOR	ERJ3GEYJ 102 V (1 kΩ)
R113	7030003680	S.RESISTOR	ERJ3GEYJ 104 V (100 kΩ)
R114	7030003680	S.RESISTOR	ERJ3GEYJ 104 V (100 kΩ)
R115	7030003680	S.RESISTOR	ERJ3GEYJ 104 V (100 kΩ)
R117	7030005320	S.RESISTOR	RR0816P-103-D (10 kΩ)
R118	7030006560	S.RESISTOR	RR0816P-223-D (22 kΩ)
R119	7030005330	S.RESISTOR	RR0816P-562-D (5.6 kΩ)

S.=Surface mount

[MAIN UNIT]

REF NO.	ORDER NO.	DESCRIPTION	
R120	7030003200	S.RESISTOR	ERJ3GEYJ 100 V (10 Ω)
R121	7030005320	S.RESISTOR	RR0816P-103-D (10 kΩ)
R122	7030006560	S.RESISTOR	RR0816P-223-D (22 kΩ)
R123	7030005330	S.RESISTOR	RR0816P-562-D (5.6 kΩ)
R124	7030003200	S.RESISTOR	ERJ3GEYJ 100 V (10 Ω)
R125	7030003460	S.RESISTOR	ERJ3GEYJ 152 V (1.5 kΩ)
R126	7030003320	S.RESISTOR	ERJ3GEYJ 101 V (100 Ω)
R127	7030003320	S.RESISTOR	ERJ3GEYJ 101 V (100 Ω)
R128	7030003270	S.RESISTOR	ERJ3GEYJ 390 V (39 Ω)
R129	7030003270	S.RESISTOR	ERJ3GEYJ 390 V (39 Ω)
R130	7030003650	S.RESISTOR	ERJ3GEYJ 563 V (56 kΩ)
R131	7030003500	S.RESISTOR	ERJ3GEYJ 332 V (3.3 kΩ)
R132	7030003440	S.RESISTOR	ERJ3GEYJ 102 V (1 kΩ)
R134	7030003520	S.RESISTOR	ERJ3GEYJ 472 V (4.7 kΩ)
R135	7030003480	S.RESISTOR	ERJ3GEYJ 222 V (2.2 kΩ)
R136	7030003560	S.RESISTOR	ERJ3GEYJ 103 V (10 kΩ)
C1	4030007100	S.CERAMIC	C1608 CH 1H 560J-T-A
C2	4030006860	S.CERAMIC	C1608 JB 1H 102K-T-A
C3	4030007140	S.CERAMIC	C1608 CH 1H 121J-T-A
C4	4030007140	S.CERAMIC	C1608 CH 1H 121J-T-A
C5	4030011600	S.CERAMIC	C1608 JB 1C 104KT-N
C6	4030012600	S.CERAMIC	C2012 JB 1A 105M-T-A
C7	4030006900	S.CERAMIC	C1608 JB 1E 103K-T-A
C8	4030006860	S.CERAMIC	C1608 JB 1H 102K-T-A
C9	4030008920	S.CERAMIC	C1608 JB 1C 473K-T-A
C10	4030007120	S.CERAMIC	C1608 CH 1H 820J-T-A
C11	4030008900	S.CERAMIC	C1608 JB 1C 333K-T-A
C12	4030006860	S.CERAMIC	C1608 JB 1H 102K-T-A
C13	4030006860	S.CERAMIC	C1608 JB 1H 102K-T-A
C14	4030012600	S.CERAMIC	C2012 JB 1A 105M-T-A
C15	4030011600	S.CERAMIC	C1608 JB 1C 104KT-N
C16	4550006210	S.TANTALUM	ECST1CX106R
C17	4030011600	S.CERAMIC	C1608 JB 1C 104KT-N
C18	4030006860	S.CERAMIC	C1608 JB 1H 102K-T-A
C19	4510005960	ELECTROLYTIC	10 MV 220 HC
C20	4510005370	S.ELECTROLYTIC	ECEV1AA221P
C21	4030011600	S.CERAMIC	C1608 JB 1C 104KT-N
C22	4030011600	S.CERAMIC	C1608 JB 1C 104KT-N
C23	4550006390	S.TANTALUM	TEMSVA 1C 335M-8L
C24	4550006390	S.TANTALUM	TEMSVA 1C 335M-8L
C25	4030011810	S.CERAMIC	C1608 JB 1A 224K-T-N
C26	4030012600	S.CERAMIC	C2012 JB 1A 105M-T-A
C27	4030012600	S.CERAMIC	C2012 JB 1A 105M-T-A
C28	4030012600	S.CERAMIC	C2012 JB 1A 105M-T-A
C29	4030011600	S.CERAMIC	C1608 JB 1C 104KT-N
C30	4030006860	S.CERAMIC	C1608 JB 1H 102K-T-A
C31	4030006860	S.CERAMIC	C1608 JB 1H 102K-T-A
C32	4030006860	S.CERAMIC	C1608 JB 1H 102K-T-A
C33	4030011600	S.CERAMIC	C1608 JB 1C 104KT-N
C34	4550006200	S.TANTALUM	ECST0JY106R
C35	4030008860	S.CERAMIC	C1608 JB 1C 153K-T-A
C36	4030011330	S.CERAMIC	C1608 CH 1H 391J-T-A
C37	4030006900	S.CERAMIC	C1608 JB 1E 103K-T-A
C38	4030008890	S.CERAMIC	C1608 JB 1C 273K-T-A
C39	4030011600	S.CERAMIC	C1608 JB 1C 104KT-N
C40	4030006900	S.CERAMIC	C1608 JB 1E 103K-T-A
C41	4030011600	S.CERAMIC	C1608 JB 1C 104KT-N
C42	4030009490	S.CERAMIC	C1608 JB 1H 821K-T-A
C43	4030010770	S.CERAMIC	C1608 JB 1H 392K-T-A
C45	4030007160	S.CERAMIC	C1608 CH 1H 181J-T-A
C46	4030008890	S.CERAMIC	C1608 JB 1C 273K-T-A
C47	4030006900	S.CERAMIC	C1608 JB 1E 103K-T-A
C48	4030008770	S.CERAMIC	C1608 JB 1H 562K-T-A
C50	4030007150	S.CERAMIC	C1608 CH 1H 151J-T-A
C51	4030008890	S.CERAMIC	C1608 JB 1C 273K-T-A
C52	4550006200	S.TANTALUM	ECST0JY106R
C53	4550006200	S.TANTALUM	ECST0JY106R
C54	4030006900	S.CERAMIC	C1608 JB 1E 103K-T-A
C55	4550006200	S.TANTALUM	ECST0JY106R
C56	4030006900	S.CERAMIC	C1608 JB 1E 103K-T-A
C57	4550006200	S.TANTALUM	ECST0JY106R
C58	4030006900	S.CERAMIC	C1608 JB 1E 103K-T-A
C59	4550006200	S.TANTALUM	ECST0JY106R
C60	4030011810	S.CERAMIC	C1608 JB 1A 224K-T-N
C61	4550006950	S.TANTALUM	ECST0JX476R
C62	4510005600	S.ELECTROLYTIC	ECEV1CS100SR
C63	4030006860	S.CERAMIC	C1608 JB 1H 102K-T-A
C64	4030006860	S.CERAMIC	C1608 JB 1H 102K-T-A
C65	4030011600	S.CERAMIC	C1608 JB 1C 104KT-N
C66	4030011600	S.CERAMIC	C1608 JB 1C 104KT-N

[MAIN UNIT]

REF NO.	ORDER NO.	DESCRIPTION	
C67	4030007090	S.CERAMIC	C1608 CH 1H 470J-T-A
C68	4030007090	S.CERAMIC	C1608 CH 1H 470J-T-A
C69	4030008650	S.CERAMIC	C1608 JB 1H 332K-T-A
C71	4030006850	S.CERAMIC	C1608 JB 1H 471K-T-A
C72	4030006900	S.CERAMIC	C1608 JB 1E 103K-T-A
C73	4030007050	S.CERAMIC	C1608 CH 1H 220J-T-A
C74	4030009650	S.CERAMIC	C1608 CH 1H 240J-T-A
C75	4030008890	S.CERAMIC	C1608 JB 1C 273K-T-A
C76	4030008920	S.CERAMIC	C1608 JB 1C 473K-T-A
C77	4030008920	S.CERAMIC	C1608 JB 1C 473K-T-A
C78	4030008920	S.CERAMIC	C1608 JB 1C 473K-T-A
C79	4030008920	S.CERAMIC	C1608 JB 1C 473K-T-A
C80	4030008920	S.CERAMIC	C1608 JB 1C 473K-T-A
C81	4030008920	S.CERAMIC	C1608 JB 1C 473K-T-A
C82	4030008920	S.CERAMIC	C1608 JB 1C 473K-T-A
C83	4030008920	S.CERAMIC	C1608 JB 1C 473K-T-A
C84	4030008920	S.CERAMIC	C1608 JB 1C 473K-T-A
C85	4030006900	S.CERAMIC	C1608 JB 1E 103K-T-A
C86	4550006200	S.TANTALUM	ECST0JY106R
C87	4030011600	S.CERAMIC	C1608 JB 1C 104KT-N
C88	4030011600	S.CERAMIC	C1608 JB 1C 104KT-N
C89	4030011600	S.CERAMIC	C1608 JB 1C 104KT-N
C90	4030011600	S.CERAMIC	C1608 JB 1C 104KT-N
C91	4030008920	S.CERAMIC	C1608 JB 1C 473K-T-A
C92	4030008920	S.CERAMIC	C1608 JB 1C 473K-T-A
C93	4030010020	S.CERAMIC	C1608 JB 1H 122K-T-A
C94	4030008860	S.CERAMIC	C1608 JB 1C 153K-T-A
J1	6510021960	S.CONNECTOR	AXN430C040P
J2	6510010960	CONNECTOR	PI28E-02M
J3	6510016430	S.CONNECTOR	53307-1491
DS1	5030001810	LCD	A0081A
DS2	5010000120	S.LED	LN1371G-(TR)
DS3	5010000120	S.LED	LN1371G-(TR)
DS4	5010000120	S.LED	LN1371G-(TR)
DS5	5010000120	S.LED	LN1371G-(TR)
DS6	5010000160	S.LED	LNJ310M6URA
DS7	5010000160	S.LED	LNJ310M6URA
DS8	5010000160	S.LED	LNJ310M6URA
DS9	5010000160	S.LED	LNJ310M6URA
MC1	7700002440	MICROPHONE	KUB2823-013280
EP1	0910051885	PCB	B 5389E
EP2	8930051120	LCD CONTACT	SRCN-2320-SP-N-W

[RF UNIT]

REF NO.	ORDER NO.	DESCRIPTION	
IC1	1130007610	S.IC	μPD3140GS-E1 (DS8)
IC2	1110004530	S.IC	M62368GP 70ED
IC3	1120002830	S.IC	NJM2125F-TE1
Q1	1560000540	S.FET	2SK880-Y (TE85R)
Q2	1590000430	S.TRANSISTOR	DTC144EUA T106
Q4	1530002920	S.TRANSISTOR	2SC4226-T2 R25
Q5	1530002920	S.TRANSISTOR	2SC4226-T2 R25
Q6	1530002600	S.TRANSISTOR	2SC4215-O (TE85R)
Q7	1530002600	S.TRANSISTOR	2SC4215-O (TE85R)
Q8	1530002600	S.TRANSISTOR	2SC4215-O (TE85R)
Q9	1530002920	S.TRANSISTOR	2SC4226-T2 R25
Q10	1560001020	S.FET	2SK2973 (MTS101P)
Q11	1560001050	S.FET	2SK2974
Q13	1580000720	S.FET	3SK239AXRTL
Q14	1580000490	S.FET	3SK166A-2-T7
Q15	1530002360	S.TRANSISTOR	2SC2714-Y (TE85R)
Q16	1530002060	S.TRANSISTOR	2SC4081 T107 R
Q17	1590002160	S.TRANSISTOR	XP6401-(TX)

S.=Surface mount

[RF UNIT]

REF NO.	ORDER NO.	DESCRIPTION	
D1	1720000670	S.VARICAP	HVU17TRF
D2	1790000620	S.DIODE	MA77 (TX)
D4	1790001650	S.DIODE	MA77 (TX) -AB
D5	1720000370	S.VARICAP	HVU350TRF
D6	1720000370	S.VARICAP	HVU350TRF
D7	1790000620	S.DIODE	MA77 (TX)
D8	1790000620	S.DIODE	MA77 (TX)
D9	1790000620	S.DIODE	MA77 (TX)
D10	1790000490	S.DIODE	HSM88AS-TR
D11	1790000620	S.DIODE	MA77 (TX)
D12	1790000620	S.DIODE	MA77 (TX)
D13	1720000370	S.VARICAP	HVU350TRF
D14	1720000370	S.VARICAP	HVU350TRF
D15	1720000370	S.VARICAP	HVU350TRF
D16	1720000370	S.VARICAP	HVU350TRF
D17	1720000370	S.VARICAP	HVU350TRF
D18	1720000370	S.VARICAP	HVU350TRF
D19	1730002300	S.ZENER	MA8082-M (TX)
FI1	2010002420	MONOLITH	21R15AB (FL-310)
FI2	2010002420	MONOLITH	21R15AB (FL-310)
X1	6050010800	S.XTAL	CR-659 (21.25 MHz)
L1	6200007000	S.COIL	ELJRE 82NG-F
L2	6200008070	S.COIL	MLF1608E 6R8K 6.8U
L3	6200003090	S.COIL	NL 322522T-2R7J-3
L5	6200006980	S.COIL	ELJRE R10G-F
L6	6200006980	S.COIL	ELJRE R10G-F
L7	6200006980	S.COIL	ELJRE R10G-F
L8	6200006980	S.COIL	ELJRE R10G-F
L9	6200006670	S.COIL	ELJRE 68NG-F
L10	6200002320	S.COIL	LQN 1A 8N8J04
L11	6200009240	S.COIL	0.20-1.0-7TL 31N
L12	6200008460	S.COIL	0.26-0.9-5TR 15N
L13	6200002370	S.COIL	LQN 1A 39NJ04
L14	6200003090	S.COIL	NL 322522T-2R7J-3
L15	6200008450	S.COIL	0.35-1.6-5TL 28N
L16	6200008450	S.COIL	0.35-1.6-5TL 28N
L17	6200008400	S.COIL	0.35-1.6-6TL 36N
L18	6200002820	S.COIL	LQN 1A 47NJ04
L19	6200002820	S.COIL	LQN 1A 47NJ04
L20	6200007160	S.COIL	LQN 1H 54NK04
L21	6200007160	S.COIL	LQN 1H 54NK04
L22	6200002360	S.COIL	LQN 1A 33NJ04
L23	6200002360	S.COIL	LQN 1A 33NJ04
L24	6200005740	S.COIL	ELJRE 47NG-F
L25	6200006980	S.COIL	ELJRE R10G-F
L26	6200004790	S.COIL	MLF1608D R47K-T
L27	6200003590	S.COIL	EXCCL3225U1
L28	6200003590	S.COIL	EXCCL3225U1
L29	6200008190	S.COIL	0.25-1.9-8TL 80N
R1	7030003760	S.RESISTOR	ERJ3GEYJ 474 V (470 kΩ)
R2	7030003640	S.RESISTOR	ERJ3GEYJ 473 V (47 kΩ)
R3	7030003380	S.RESISTOR	ERJ3GEYJ 331 V (330 Ω)
R4	7510001160	S.THERMISTOR	NTCCM1608 4LH 473KC
R5	7030005870	S.RESISTOR	RR0816R-104-D (100 kΩ)
R6	7030003440	S.RESISTOR	ERJ3GEYJ 102 V (1 kΩ)
R7	7030003560	S.RESISTOR	ERJ3GEYJ 103 V (10 kΩ)
R8	7030003640	S.RESISTOR	ERJ3GEYJ 473 V (47 kΩ)
R9	7030003320	S.RESISTOR	ERJ3GEYJ 101 V (100 Ω)
R10	7030003440	S.RESISTOR	ERJ3GEYJ 102 V (1 kΩ)
R11	7030003200	S.RESISTOR	ERJ3GEYJ 100 V (10 Ω)
R12	7030003510	S.RESISTOR	ERJ3GEYJ 392 V (3.9 kΩ)
R13	7030003410	S.RESISTOR	ERJ3GEYJ 561 V (560 Ω)
R14	7030003660	S.RESISTOR	ERJ3GEYJ 683 V (68 kΩ)
R15	7030003580	S.RESISTOR	ERJ3GEYJ 153 V (15 kΩ)
R16	7030003680	S.RESISTOR	ERJ3GEYJ 104 V (100 kΩ)
R17	7030003680	S.RESISTOR	ERJ3GEYJ 104 V (100 kΩ)
R19	7030003440	S.RESISTOR	ERJ3GEYJ 102 V (1 kΩ)
R20	7030003640	S.RESISTOR	ERJ3GEYJ 473 V (47 kΩ)
R22	7030003440	S.RESISTOR	ERJ3GEYJ 102 V (1 kΩ)
R23	7030003550	S.RESISTOR	ERJ3GEYJ 822 V (8.2 kΩ)
R24	7030003550	S.RESISTOR	ERJ3GEYJ 822 V (8.2 kΩ)
R26	7030003390	S.RESISTOR	ERJ3GEYJ 391 V (390 Ω)
R27	7030003350	S.RESISTOR	ERJ3GEYJ 181 V (180 Ω)
R28	7030003660	S.RESISTOR	ERJ3GEYJ 683 V (68 kΩ)

[RF UNIT]

REF NO.	ORDER NO.	DESCRIPTION	
R29	7030003420	S.RESISTOR	ERJ3GEYJ 681 V (680 Ω)
R30	7030003660	S.RESISTOR	ERJ3GEYJ 683 V (68 kΩ)
R31	7030003400	S.RESISTOR	ERJ3GEYJ 471 V (470 Ω)
R32	7030003630	S.RESISTOR	ERJ3GEYJ 393 V (39 kΩ)
R33	7030003390	S.RESISTOR	ERJ3GEYJ 391 V (390 Ω)
R34	7030003520	S.RESISTOR	ERJ3GEYJ 472 V (4.7 kΩ)
R35	7030004050	S.RESISTOR	ERJ3GEYJ 1R0 V (1 Ω)
R36	7030003320	S.RESISTOR	ERJ3GEYJ 101 V (100 Ω)
R37	7030003520	S.RESISTOR	ERJ3GEYJ 472 V (4.7 kΩ)
R38	7030003500	S.RESISTOR	ERJ3GEYJ 332 V (3.3 kΩ)
R39	7030003450	S.RESISTOR	ERJ3GEYJ 122 V (1.2 kΩ)
R40	7030003310	S.RESISTOR	ERJ3GEYJ 820 V (82 Ω)
R41	7030003260	S.RESISTOR	ERJ3GEYJ 330 V (33 Ω)
R42	7030003560	S.RESISTOR	ERJ3GEYJ 103 V (10 kΩ)
R43	7030003580	S.RESISTOR	ERJ3GEYJ 153 V (15 kΩ)
R44	7030003320	S.RESISTOR	ERJ3GEYJ 101 V (100 Ω)
R46	7030003280	S.RESISTOR	ERJ3GEYJ 470 V (47 Ω)
R47	7030003440	S.RESISTOR	ERJ3GEYJ 102 V (1 kΩ)
R48	7030003320	S.RESISTOR	ERJ3GEYJ 101 V (100 Ω)
R49	7030003560	S.RESISTOR	ERJ3GEYJ 103 V (10 kΩ)
R51	7030000280	S.RESISTOR	MCR10EZHZH 150 Ω (151)
R52	7030003670	S.RESISTOR	ERJ3GEYJ 823 V (82 kΩ)
R53	7030003600	S.RESISTOR	ERJ3GEYJ 223 V (22 kΩ)
R54	7030003460	S.RESISTOR	ERJ3GEYJ 152 V (1.5 kΩ)
R56	7030003310	S.RESISTOR	ERJ3GEYJ 820 V (82 Ω)
R57	7030003800	S.RESISTOR	ERJ3GEYJ 105 V (1 MΩ)
R58	7030003680	S.RESISTOR	ERJ3GEYJ 104 V (100 kΩ)
R59	7030003800	S.RESISTOR	ERJ3GEYJ 105 V (1 MΩ)
R60	7030003680	S.RESISTOR	ERJ3GEYJ 104 V (100 kΩ)
R61	7030003780	S.RESISTOR	ERJ3GEYJ 684 V (680 kΩ)
R62	7030003720	S.RESISTOR	ERJ3GEYJ 224 V (220 kΩ)
R63	7030003770	S.RESISTOR	ERJ3GEYJ 564 V (560 kΩ)
R64	7030003780	S.RESISTOR	ERJ3GEYJ 684 V (680 kΩ)
R65	7030003360	S.RESISTOR	ERJ3GEYJ 221 V (22 Ω)
R67	7030003200	S.RESISTOR	ERJ3GEYJ 100 V (10 Ω)
R68	7030003680	S.RESISTOR	ERJ3GEYJ 104 V (100 kΩ)
R69	7030003800	S.RESISTOR	ERJ3GEYJ 105 V (1 MΩ)
R70	7030003680	S.RESISTOR	ERJ3GEYJ 104 V (100 kΩ)
R71	7030003800	S.RESISTOR	ERJ3GEYJ 105 V (1 MΩ)
R72	7030003680	S.RESISTOR	ERJ3GEYJ 104 V (100 kΩ)
R73	7030003320	S.RESISTOR	ERJ3GEYJ 101 V (100 Ω)
R74	7030003520	S.RESISTOR	ERJ3GEYJ 472 V (4.7 kΩ)
R78	7030003680	S.RESISTOR	ERJ3GEYJ 104 V (100 kΩ)
R80	7030003340	S.RESISTOR	ERJ3GEYJ 151 V (150 Ω)
R82	7030003200	S.RESISTOR	ERJ3GEYJ 100 V (10 Ω)
R83	7030003460	S.RESISTOR	ERJ3GEYJ 152 V (1.5 kΩ)
R86	7030003460	S.RESISTOR	ERJ3GEYJ 152 V (1.5 kΩ)
R87	7030003440	S.RESISTOR	ERJ3GEYJ 102 V (1 kΩ)
R88	7030003680	S.RESISTOR	ERJ3GEYJ 104 V (100 kΩ)
R89	7030003400	S.RESISTOR	ERJ3GEYJ 471 V (470 Ω)
R90	7030005320	S.RESISTOR	RR0816P-103-D (10 kΩ)
R91	7030008120	S.RESISTOR	RR0816P-682-D (6.8 kΩ)
R92	7030003440	S.RESISTOR	ERJ3GEYJ 102 V (1 kΩ)
R95	7030003440	S.RESISTOR	ERJ3GEYJ 102 V (1 kΩ)
R96	7030003580	S.RESISTOR	ERJ3GEYJ 153 V (15 kΩ)
R97	7030003440	S.RESISTOR	ERJ3GEYJ 102 V (1 kΩ)
R98	7030007330	S.RESISTOR	ERJ1WRSJR15U (0.15 Ω)
R99	7030003560	S.RESISTOR	ERJ3GEYJ 103 V (10 kΩ)
R100	7030003680	S.RESISTOR	ERJ3GEYJ 104 V (100 kΩ)
R101	7030003560	S.RESISTOR	ERJ3GEYJ 103 V (10 kΩ)
R102	7030003680	S.RESISTOR	ERJ3GEYJ 104 V (100 kΩ)
R103	7030003320	S.RESISTOR	ERJ3GEYJ 101 V (100 Ω)
R104	7030003620	S.RESISTOR	ERJ3GEYJ 333 V (33 kΩ)
R105	7030003560	S.RESISTOR	ERJ3GEYJ 103 V (10 kΩ)
C1	4030006900	S.CERAMIC	C1608 JB 1E 103K-T-A
C2	4030007170	S.CERAMIC	C1608 CH 1H 221J-T-A
C3	4030007010	S.CERAMIC	C1608 CH 1H 100D-T-A
C4	4030007020	S.CERAMIC	C1608 CH 1H 120J-T-A
C5	4030008630	S.CERAMIC	C1608 JF 1C 104Z-T-A
C6	4030006860	S.CERAMIC	C1608 JB 1H 102K-T-A
C7	4030006860	S.CERAMIC	C1608 JB 1H 102K-T-A
C8	4030007000	S.CERAMIC	C1608 CH 1H 090D-T-A
C9	4030007000	S.CERAMIC	C1608 CH 1H 090D-T-A
C10	4030006860	S.CERAMIC	C1608 JF 1H 102K-T-A
C11	4030006900	S.CERAMIC	C1608 JB 1E 103K-T-A
C13	4030009520	S.CERAMIC	C1608 CH 1H 020B-T-A
C15	4030009520	S.CERAMIC	C1608 CH 1H 020B-T-A
C16	4550000510	S.TANTALUM	TESVA 1V 473M1-8L
C17	4550006140	S.TANTALUM	ECST1EY474R

[M1EURO V] only

S.=Surface mount

[RF UNIT]

REF NO.	ORDER NO.	DESCRIPTION	
C18	4030011600	S.CERAMIC	C1608 JB 1C 104KT-N
C19	4030006860	S.CERAMIC	C1608 JB 1H 102K-T-A
C20	4030011600	S.CERAMIC	C1608 JB 1C 104KT-N
C21	4030008650	S.CERAMIC	C1608 JB 1H 332K-T-A
C22	4030006860	S.CERAMIC	C1608 JB 1H 102K-T-A
C23	4030008770	S.CERAMIC	C1608 JB 1H 562K-T-A
C24	4030006860	S.CERAMIC	C1608 JB 1H 102K-T-A
C25	4550006200	S.TANTALUM	ECST0JY106R
C27	4030006860	S.CERAMIC	C1608 JB 1H 102K-T-A
C28	4030006860	S.CERAMIC	C1608 JB 1H 102K-T-A
C29	4030007090	S.CERAMIC	C1608 CH 1H 470J-T-A
C30	4030007080	S.CERAMIC	C1608 CH 1H 390J-T-A
C31	4030009540	S.CERAMIC	C1608 CH 1H 1R5B-T-A
C32	4030009540	S.CERAMIC	C1608 CH 1H 1R5B-T-A
C33	4030007170	S.CERAMIC	C1608 CH 1H 221J-T-A
C34	4030006860	S.CERAMIC	C1608 JB 1H 102K-T-A
C35	4030006860	S.CERAMIC	C1608 JB 1H 102K-T-A
C36	4030009570	S.CERAMIC	C1608 CH 1H 0R3B-T-A
C37	4030006860	S.CERAMIC	C1608 JB 1H 102K-T-A
C38	4030009920	S.CERAMIC	C1608 CH 1H 050B-T-A
C39	4030006860	S.CERAMIC	C1608 JB 1H 102K-T-A
C40	4030007050	S.CERAMIC	C1608 CH 1H 220J-T-A
C41	4030007020	S.CERAMIC	C1608 CH 1H 120J-T-A
C42	4030006860	S.CERAMIC	C1608 JB 1H 102K-T-A
C43	4030007040	S.CERAMIC	C1608 CH 1H 180J-T-A
C44	4030006860	S.CERAMIC	C1608 JB 1H 102K-T-A
C45	4030007050	S.CERAMIC	C1608 CH 1H 220J-T-A
C46	4030006860	S.CERAMIC	C1608 JB 1H 102K-T-A
C47	4030006860	S.CERAMIC	C1608 JB 1H 102K-T-A
C48	4030007030	S.CERAMIC	C1608 CH 1H 150J-T-A
C49	4030009650	S.CERAMIC	C1608 CH 1H 240J-T-A
C50	4550006200	S.TANTALUM	ECST0JY106R
C52	4030006860	S.CERAMIC	C1608 JB 1H 102K-T-A
C53	4030006860	S.CERAMIC	C1608 JB 1H 102K-T-A
C56	4510004870	S.ELECTROLYTIC	ECEV1CA330P
C57	4030006860	S.CERAMIC	C1608 JB 1H 102K-T-A
C58	4030006860	S.CERAMIC	C1608 JB 1H 102K-T-A
C59	4030011340	S.CERAMIC	C1608 CH 1H 471J-T-A
C61	4030006860	S.CERAMIC	C1608 JB 1H 102K-T-A
C63	4030006860	S.CERAMIC	C1608 JB 1H 102K-T-A
C64	4030007090	S.CERAMIC	C1608 CH 1H 470J-T-A
C66	4030008560	S.CERAMIC	C1608 CH 1H 300J-T-A
C67	4030011540	S.CERAMIC	C1608 CH 1H 750J-T-A
C68	4030007040	S.CERAMIC	C1608 CH 1H 180J-T-A
C69	4030006860	S.CERAMIC	C1608 JB 1H 102K-T-A
C71	4030006860	S.CERAMIC	C1608 JB 1H 102K-T-A
C72	4030006860	S.CERAMIC	C1608 JB 1H 102K-T-A
C73	4030009530	S.CERAMIC	C1608 CH 1H 030B-T-A
C74	4030007010	S.CERAMIC	C1608 CH 1H 100D-T-A
	4030011530	S.CERAMIC	C1608 CH 1H 110J-T-A
			[M1V]
			[M1EURO V]
C75	4030007020	S.CERAMIC	C1608 CH 1H 120J-T-A
	4030011530	S.CERAMIC	C1608 CH 1H 110J-T-A
			[M1EURO V]
C76	4030009350	S.CERAMIC	C1608 CH 1H 3R5B-T-A
	4030009910	S.CERAMIC	C1608 CH 1H 040B-T-A
			[M1EURO V]
C77	4030007030	S.CERAMIC	C1608 CH 1H 150J-T-A
C79	4030009500	S.CERAMIC	C1608 CH 1H 0R5B-T-A
			[M1EURO V] only
C80	4030009520	S.CERAMIC	C1608 CH 1H 020B-T-A
C81	4030006860	S.CERAMIC	C1608 JB 1H 102K-T-A
C83	4030007040	S.CERAMIC	C1608 CH 1H 180J-T-A
C84	4030007050	S.CERAMIC	C1608 CH 1H 220J-T-A
C85	4030007010	S.CERAMIC	C1608 CH 1H 100D-T-A
C86	4030006860	S.CERAMIC	C1608 JB 1H 102K-T-A
			[M1EURO V] only
C87	4030009910	S.CERAMIC	C1608 CH 1H 040B-T-A
C88	4030009350	S.CERAMIC	C1608 CH 1H 3R5B-T-A
C89	4030007130	S.CERAMIC	C1608 CH 1H 101J-T-A
C90	4030006860	S.CERAMIC	C1608 JB 1H 102K-T-A
C91	4030009540	S.CERAMIC	C1608 CH 1H 1R5B-T-A
C93	4030006860	S.CERAMIC	C1608 JB 1H 102K-T-A
C94	4030007140	S.CERAMIC	C1608 CH 1H 121J-T-A
C95	4030009920	S.CERAMIC	C1608 CH 1H 050B-T-A
C96	4030009910	S.CERAMIC	C1608 CH 1H 040B-T-A
C97	4030006860	S.CERAMIC	C1608 JB 1H 102K-T-A
C98	4030006900	S.CERAMIC	C1608 JB 1E 103K-T-A
C99	4030006860	S.CERAMIC	C1608 JB 1H 102K-T-A
C100	4030006860	S.CERAMIC	C1608 JB 1H 102K-T-A
C101	4030006860	S.CERAMIC	C1608 JB 1H 102K-T-A
C102	4030006990	S.CERAMIC	C1608 CH 1H 080D-T-A

[RF UNIT]

REF NO.	ORDER NO.	DESCRIPTION	
C103	4030007130	S.CERAMIC	C1608 CH 1H 101J-T-A
C104	4030006860	S.CERAMIC	C1608 JB 1H 102K-T-A
C105	4030009540	S.CERAMIC	C1608 CH 1H 1R5B-T-A
C107	4030006860	S.CERAMIC	C1608 JB 1H 102K-T-A
C108	4030007130	S.CERAMIC	C1608 CH 1H 101J-T-A
C109	4030006990	S.CERAMIC	C1608 CH 1H 080D-T-A
C110	4030006860	S.CERAMIC	C1608 JB 1H 102K-T-A
C111	4030009920	S.CERAMIC	C1608 CH 1H 050B-T-A
C112	4030007070	S.CERAMIC	C1608 CH 1H 330J-T-A
C113	4030007100	S.CERAMIC	C1608 CH 1H 560J-T-A
C114	4030011530	S.CERAMIC	C1608 CH 1H 110J-T-A
C116	4030006860	S.CERAMIC	C1608 JB 1H 102K-T-A
C117	4030006900	S.CERAMIC	C1608 JB 1E 103K-T-A
C118	4030007140	S.CERAMIC	C1608 CH 1H 121J-T-A
C119	4030006860	S.CERAMIC	C1608 JB 1H 102K-T-A
C120	4030006860	S.CERAMIC	C1608 JB 1H 102K-T-A
C121	4030006900	S.CERAMIC	C1608 JB 1E 103K-T-A
C123	4030006970	S.CERAMIC	C1608 CH 1H 060D-T-A
C126	4030006900	S.CERAMIC	C1608 JB 1E 103K-T-A
C127	4550006200	S.TANTALUM	ECST0JY106R
C128	4030006900	S.CERAMIC	C1608 JB 1E 103K-T-A
C129	4550006200	S.TANTALUM	ECST0JY106R
C130	4030006900	S.CERAMIC	C1608 JB 1E 103K-T-A
C131	4550006200	S.TANTALUM	ECST0JY106R
C132	4030006900	S.CERAMIC	C1608 JB 1E 103K-T-A
C133	4030006860	S.CERAMIC	C1608 JB 1H 102K-T-A
C134	4030006860	S.CERAMIC	C1608 JB 1H 102K-T-A
C135	4030006860	S.CERAMIC	C1608 JB 1H 102K-T-A
C136	4030006860	S.CERAMIC	C1608 JB 1H 102K-T-A
C137	4030006860	S.CERAMIC	C1608 JB 1H 102K-T-A
C138	4030006860	S.CERAMIC	C1608 JB 1H 102K-T-A
C139	4030006860	S.CERAMIC	C1608 JB 1H 102K-T-A
C140	4030011600	S.CERAMIC	C1608 JB 1C 104KT-N
C141	4030006860	S.CERAMIC	C1608 JB 1H 102K-T-A
C142	4030006900	S.CERAMIC	C1608 JB 1E 103K-T-A
J1	6510021970	S.CONNECTOR	AXN330C130P
J2	6510021950	CONNECTOR	IMSA-9230B-1-07Z107-T
S1	2230000900	S.SWITCH	JPM1990-2013R
S2	2230000900	S.SWITCH	JPM1990-2013R
W1	7120000470	JUMPER	ERDS2T0
W2	7120000470	JUMPER	ERDS2T0
EP1	0910051892	PCB	B 5390B
	0910052961	PCB	B 5510A
			[M1V]
			[M1EURO V]

[VR UNIT]

REF NO.	ORDER NO.	DESCRIPTION	
R1	7210003100	VARIABLE	TP76D995N-20F-C103-A103-2320A
EP1	0910051902	PCB	B 5391B
	0910052972	PCB	B 5391B
			[M1V]
			[M1EURO V]

S.=Surface mount

SECTION 7 MECHANICAL PARTS AND DISASSEMBLY

[CHASSIS PARTS]

REF NO.	ORDER NO.	DESCRIPTION	QTY.
J1	6510019610	SMA-R209	1
J2	6510021940	246S-550-4P	1
J3	6510021930	2320 Contact	1
SP1	2510000930	SU-36W08040C	1
WS1	8600036580	FX2320 P01CH	1
MP1	8210016481	2320 Front panel-1 [IC-M1V]	1
	8210016681	2320 Front panel (A) -1 [ITA], [UK]	1
	8210016691	2320 Front panel (B) -1 [EUR], [FRG]	1
MP3	8930050730	2320 Key board [IC-M1V]	1
	8930051080	2320 Key board [IC-M1EURO V]	1
MP5	8930039000	1757 Sheet	1
MP6	8930050680	2320 Main seal	1
MP7	8210016492	2320 Rear panel-2	1
MP8	8110007021	2320 Release cover-1	1
MP9	8930050700	2320 Release button	1
MP10	8930051490	Push spring (AF)	2
MP11	8810009290	Screw PH No.0 M2 × 3 SUS ZK	2
MP12	8930050690	2320 PTT rubber	1
MP13	8310047210	2320 PTT plate	1
MP14	8810009290	Screw PH No.0 M2 × 3 SUS ZK	2
MP15	8930050711	2320 Rubber-1	1
MP16	8930050671	2320 C rubber-1	1
MP17	8810009290	Screw PH No.0 M2 × 3 SUS ZK	2
MP18	8610010760	Knob N274	1
MP19	8610010770	Knob N275	1
MP20	8930051500	O ring (AB)	1
MP21	8830001470	VR nut (N)	1
MP22	8930039840	1757 Ant seal	1
MP23	8830001160	VR nut (K)	1
MP24	8930039850	Sealing washer (J)	1
MP25	8810009340	Screw PH M2 × 5 SUS ZK	1
MP26	8830001480	VR nut (O)	1
MP27	8930050660	2320 Connector cap	1
MP28	8810008970	Screw FH BT No.0 M2 × 3.5 NI-ZU	3
MP29	8810009560	Screw PH BT M2 × 6 ZK	2
MP30	8810008970	Screw FH BT M2 × 3.5 NI-ZU	7
MP31	8810009170	Screw PH B0 M2 × 5 SUS ZK	4
MP32	8810009160	Screw PH B0 M2 × 20 SUS ZK	2

[MAIN UNIT]

REF NO.	ORDER NO.	DESCRIPTION	QTY.
DS1	5030001810	A0081A	1
EP2	8930051120	SRCN-2320-SP-N-W	2
MP4	8930050490	2320 LCD holder	1
MP5	8210016430	2320 Reflector	1

[RF UNIT]

REF NO.	ORDER NO.	DESCRIPTION	QTY.
MP2	8510012710	2320 VCO cover	1

Screw abbreviations

B0, BT: Self-tapping PH: Pan head FH: Flat head
 NI-ZU: Nickel-Zinc SUS: Stainless ZK: Black

[ACCESSORIES]

REF NO.	ORDER NO.	DESCRIPTION	QTY.
EP1	Optional product	Antenna FA-S57V-1	1
EP2	Optional product	Charger BC-122A [USA]	1
		Charger BC-122E [SEA], [ITA], [EUR], [FRG]	1
EP3	Optional product	Battery BP-215 ACC	1
EP4	Optional product	Adapter EX-2329 (AD-95 ACC)	1
MP1	8010018080	Strap belt HK-009	1
MP2	8930039290	1757 Belt clip	1
MP3	8810009270	Screw M3 × 4 SUS ZK	1

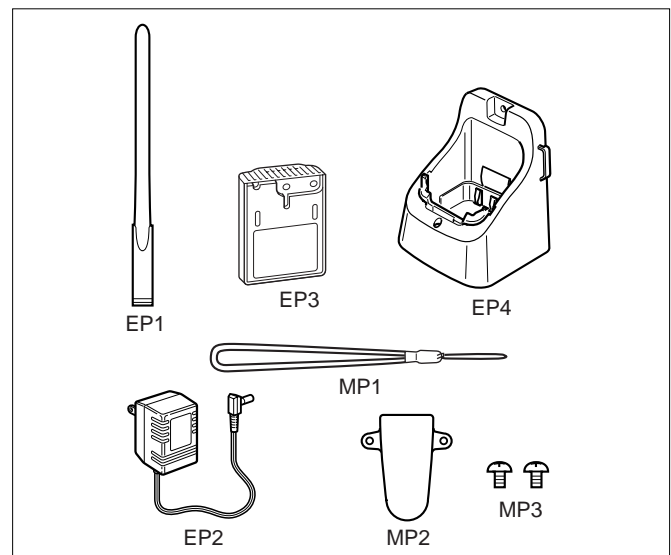

Unit abbreviations: (C): CHASSIS
(M): MAIN UNIT
(R): RF UNIT

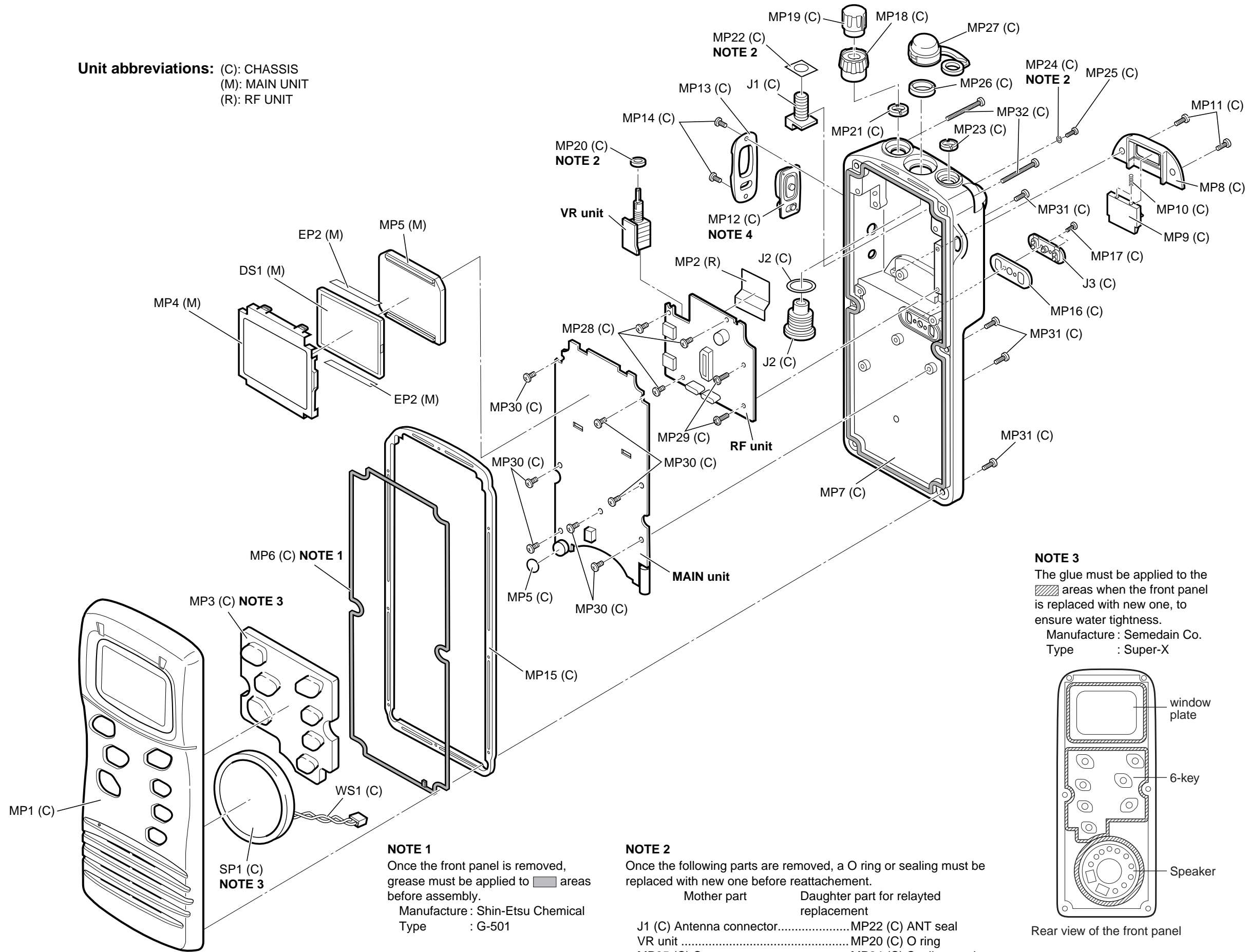

NOTE 1
Once the front panel is removed, grease must be applied to  areas before assembly.
Manufacture : Shin-Etsu Chemical
Type : G-501

NOTE 2
Once the following parts are removed, a O ring or sealing must be replaced with new one before reattachment.
Mother part Daughter part for relayed replacement
J1 (C) Antenna connector.....MP22 (C) ANT seal
VR unitMP20 (C) O ring
MP25 (C) Screw.....MP24 (C) Sealing washer

NOTE 3
The glue must be applied to the  areas when the front panel is replaced with new one, to ensure water tightness.
Manufacture : Semedain Co.
Type : Super-X

NOTE 4
Once the PTT rubber (MP12 (C)) is removed, the glue must be applied between the PTT rubber and rear panel.

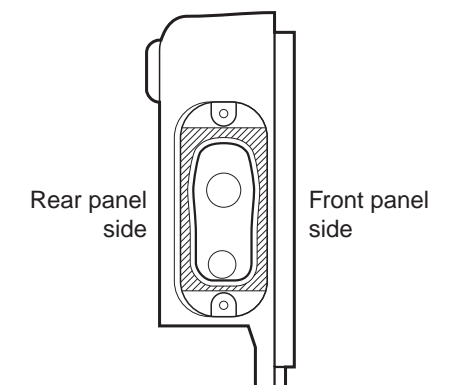
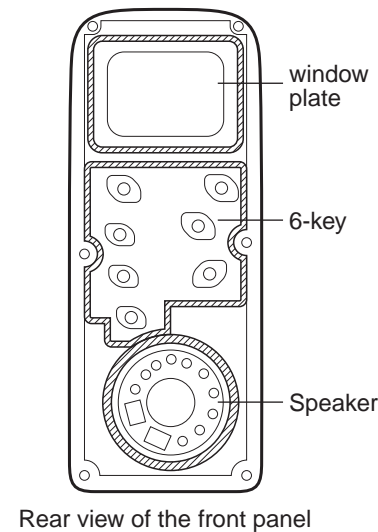

• AD-95 CHARGER PARTS LIST

ELECTRICAL PARTS

[CHARGE UNIT]

REF NO.	ORDER NO.	DESCRIPTION
IC1	1190001180	S.IC MM1332BFBE
IC2	1180001160	S.IC S-80740SN-D4-T1
Q1	1540000550	S.TRANSISTOR 2SD1664 T100Q
Q2	1590002880	S.FET 2SJ417-TL
Q3	1520000450	S.TRANSISTOR 2SB1132 T100 Q
Q4	1510000500	S.TRANSISTOR 2SA1162-GR (TE85R)
Q5	1510000500	S.TRANSISTOR 2SA1162-GR (TE85R)
Q6	1530001950	S.TRANSISTOR 2SC2712-GR (TE85R)
D1	1790000670	S.DIODE SB07-03C-TB
D2	1730002540	S.ZENER MA8130-L (TX)
D3	1750000130	S.DIODE DA204U T107
D4	1730002460	S.ZENER MA8330-M (TX)
R1	7030000380	S.RESISTOR MCR10EZHZJ 1 kΩ
R2	7030000140	S.RESISTOR MCR10EZHZJ 10 Ω (100)
R3	7030000140	S.RESISTOR MCR10EZHZJ 10 Ω (100)
R4	7030000530	S.RESISTOR MCR10EZHZJ 18 kΩ
R5	7030000580	S.RESISTOR MCR10EZHZJ 47 kΩ
R6	7030000420	S.RESISTOR MCR10EZHZJ 2.2 kΩ
R7	7030000020	S.RESISTOR MCR10EZHZJ 1 Ω (010)
R8	7030000020	S.RESISTOR MCR10EZHZJ 1 Ω (010)
R9	7030000420	S.RESISTOR MCR10EZHZJ 2.2 kΩ
R10	7030000420	S.RESISTOR MCR10EZHZJ 2.2 kΩ
R11	7030000500	S.RESISTOR MCR10EZHZJ 10 kΩ
R12	7030000570	S.RESISTOR MCR10EZHZJ 39 kΩ
R13	7520000180	S.POSISTOR PTH9C32 BE 471Q-T
R14	7030000580	S.RESISTOR MCR10EZHZJ 47 kΩ
R15	7030004490	S.RESISTOR MCR10EZHFX 12.1 kΩ
R16	7030002860	S.RESISTOR MCR10EZHFX 8.2 kΩ
R19	7030000570	S.RESISTOR MCR10EZHZJ 39 kΩ
C1	4030004750	S.CERAMIC C2012 JB 1H 103K-T-A
C2	4510005380	ELECTROLYTIC 25 MV 47 HWS (5X11)
C3	4030004750	S.CERAMIC C2012 JB 1H 103K-T-A
C5	4510006160	ELECTROLYTIC 25 MV 10 HC
C6	4030004750	S.CERAMIC C2012 JB 1H 103K-T-A
C7	4030004750	S.CERAMIC C2012 JB 1H 103K-T-A
C8	4030004750	S.CERAMIC C2012 JB 1H 103K-T-A
C9	4030004720	S.CERAMIC C2012 JB 1H 102K-T-A
C10	4030004720	S.CERAMIC C2012 JB 1H 102K-T-A
J1	6450000410	CONNECTOR HEC0470-01-630
DS1	5040001390	LED TLG124A
W1	7030003970	S.JUMPER MCR18EZHZJ JPW (000)
W2	7030003970	S.JUMPER MCR18EZHZJ JPW (000)
W3	7030003970	S.JUMPER MCR18EZHZJ JPW (000)
W4	7030003970	S.JUMPER MCR18EZHZJ JPW (000)
W5	7030003970	S.JUMPER MCR18EZHZJ JPW (000)
EP1	0910051992	PCB B 5392B
EP2	6910013110	SPACER TLE60-20

S.=Surface mount

MECHANICAL PARTS

[CHASSIS]

REF NO.	ORDER NO.	DESCRIPTION	QTY.
MP1	8010018010	2329 Case	1
MP2	8930051060	2329 Lock plate	1
MP3	8810008660	Screw PH BT B0 3 × 8 NI-ZU	1
MP4	8110007040	2329 Cover	1
MP5	8810008660	Screw PH BT B0 3 × 8 NI-ZU	3
MP6	8930039620	Leg cushion (A)	2

[CHARGE UNIT]

REF NO.	ORDER NO.	DESCRIPTION	QTY.
MP1	8930051050	2329 Terminal	1
MP2	8930051050	2329 Terminal	1
MP3	8930051050	2329 Terminal	1

Screw abbreviations B0, BT: Self-tapping PH: Pan head NI-ZU: Nickel-Zinc

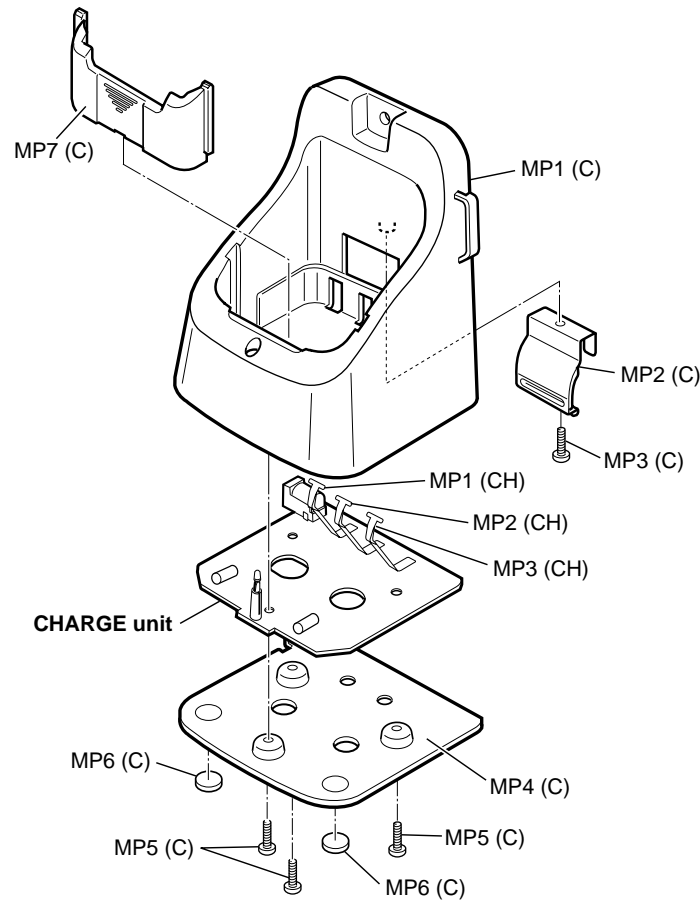

NOTE: (C) : CHASSIS (CH): CHARGE UNIT

• AD-95 VOLTAGE DIAGRAM

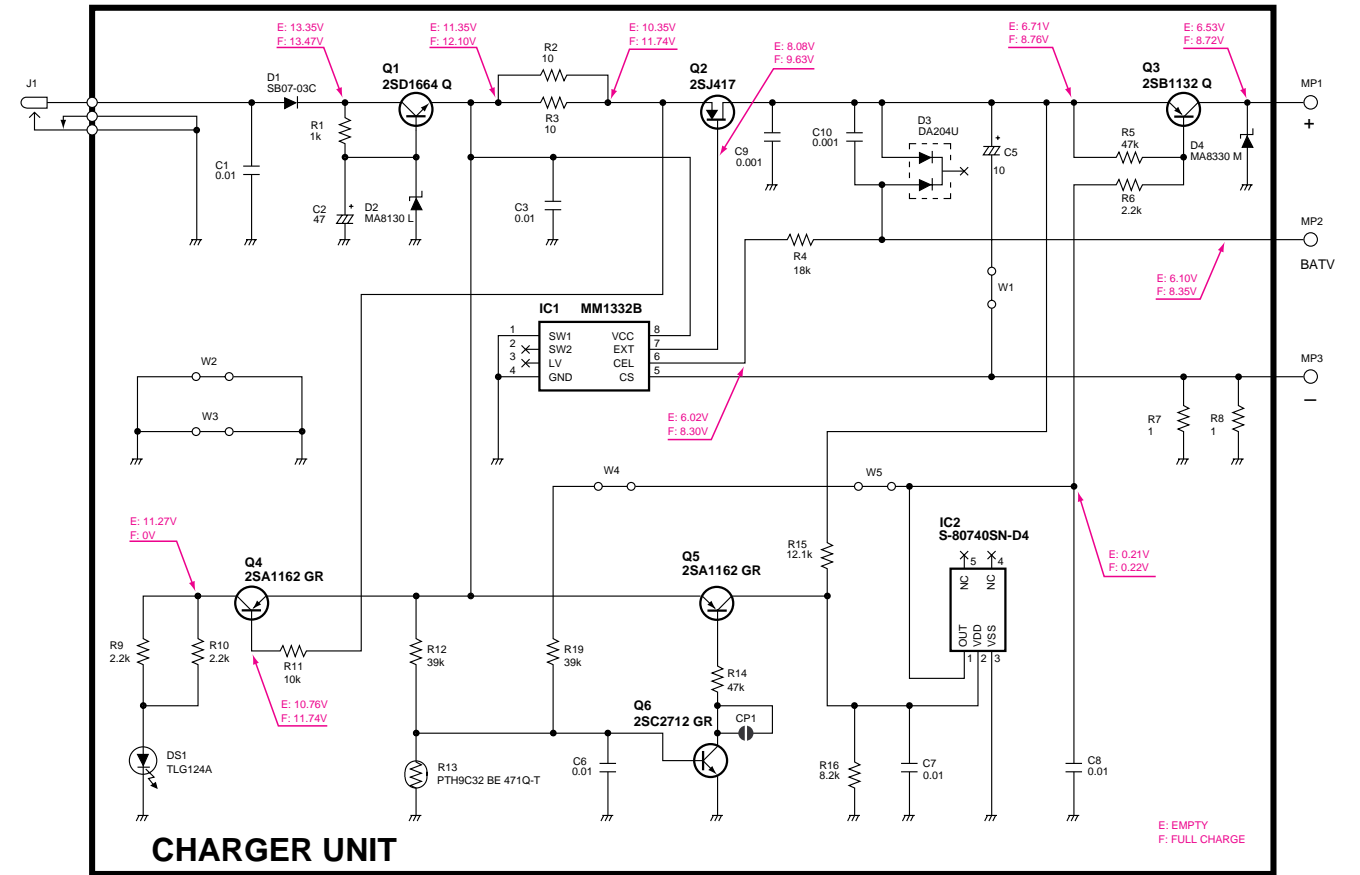

SECTION 8 SEMI-CONDUCTOR INFORMATION

8 - 1 TRANSISTORS AND FETS

NAME	SYMBOL	INSIDE VIEW
2SA1588 GR 2SA1162 GR	ZG SG	
2SB1132 R 2SB1132 Q	BARB BAQ	
2SC2712 Y 2SC2712 GR 2SC2714 Y 2SC4081 R 2SC4215 O 2SC4226 R25	LY LG QY BR QO R25	
2SD1664 Q	DAQ	
2SJ417-TL	J417	
2SK2973	K1	
2SK2974	K2974	

NAME	SYMBOL	INSIDE VIEW
2SK880 Y	XY	
3SK166 2 3SK239A	K AXR	
DTC144EU	26	
DTC144TU	06	
UN911F	60	
XP6401	50	
XP6501 AB	5N	

8 - 2 DIODES

NAME	SYMBOL	INSIDE VIEW
DA204U HSM88AS TR	K C1	
HVU17TRF	E	
HVU350TRF	4	
MA8082 M MA8130 L MA8330 M	8-2 13- 33-	
MA77 MA77 AB	4B 4B	
SB07-03C	J	

SECTION 9 BOARD LAYOUTS

9 - 1 CHARGE UNIT (AD-95)

• TOP VIEW

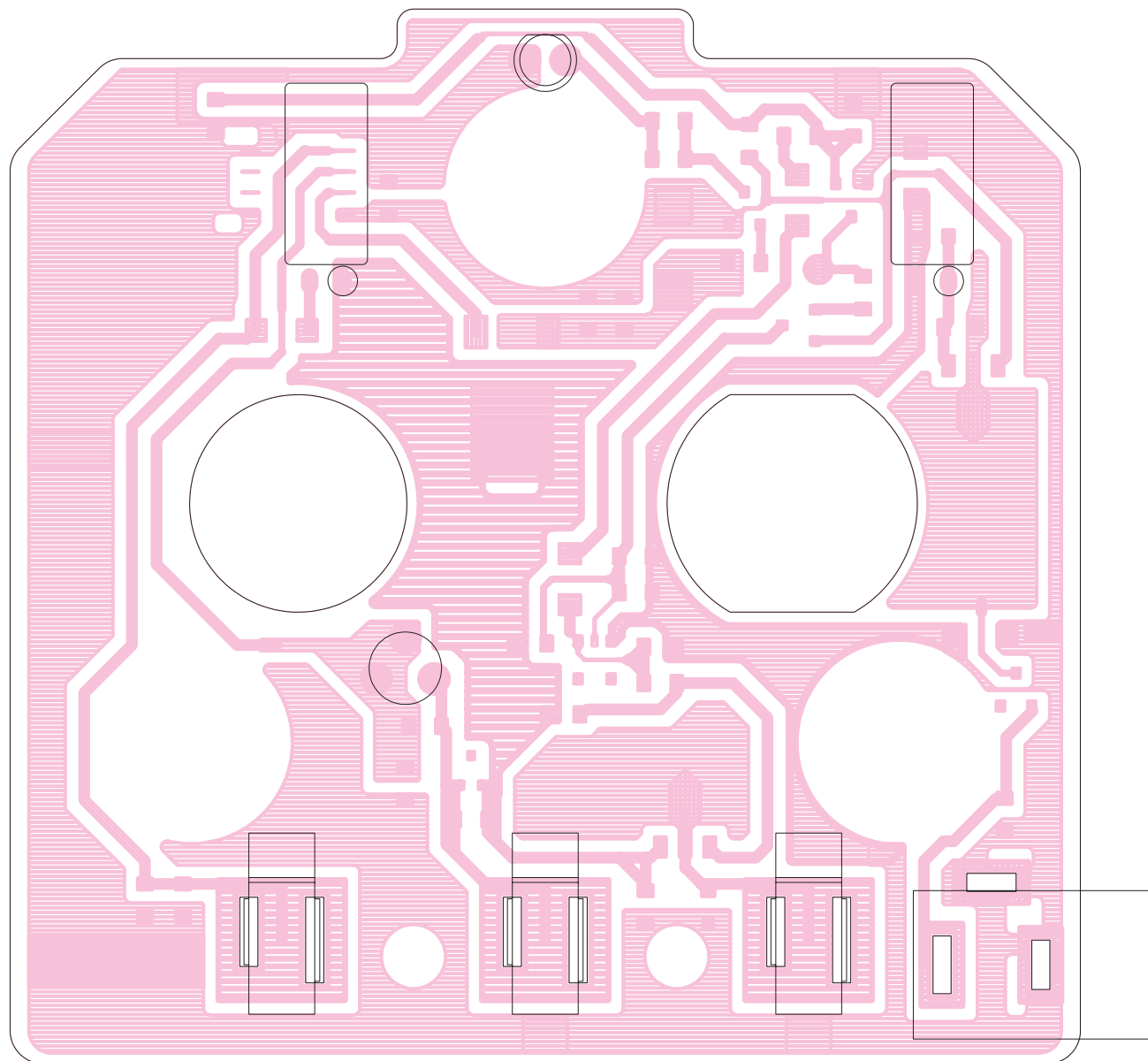

• BOTTOM VIEW

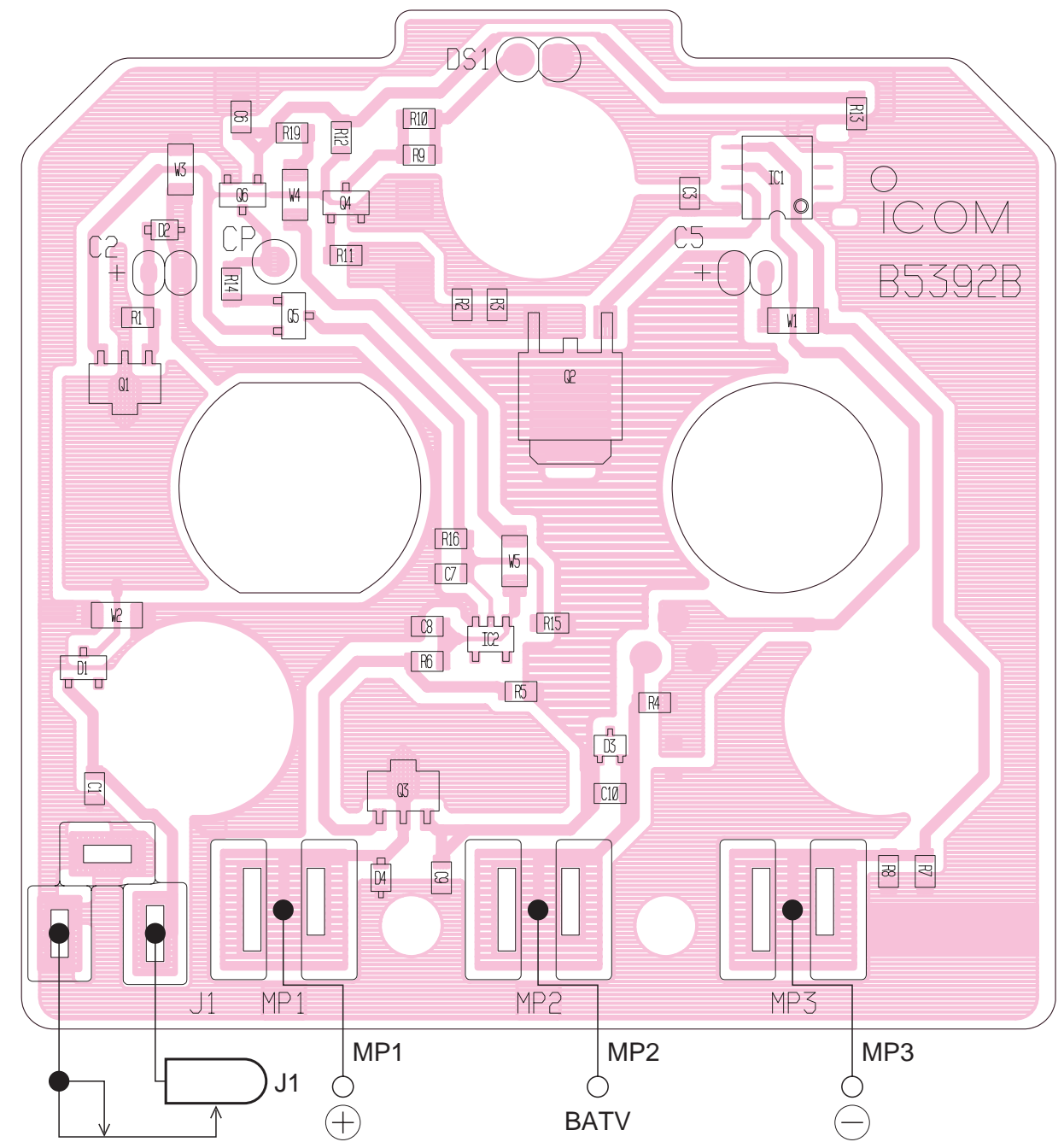

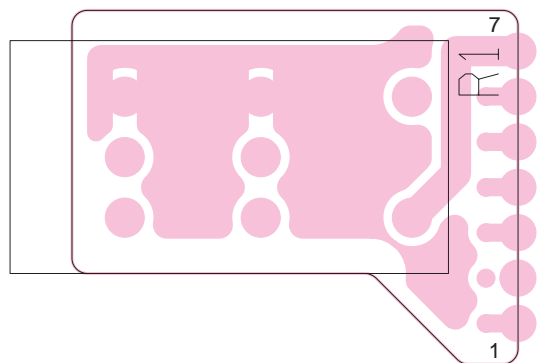
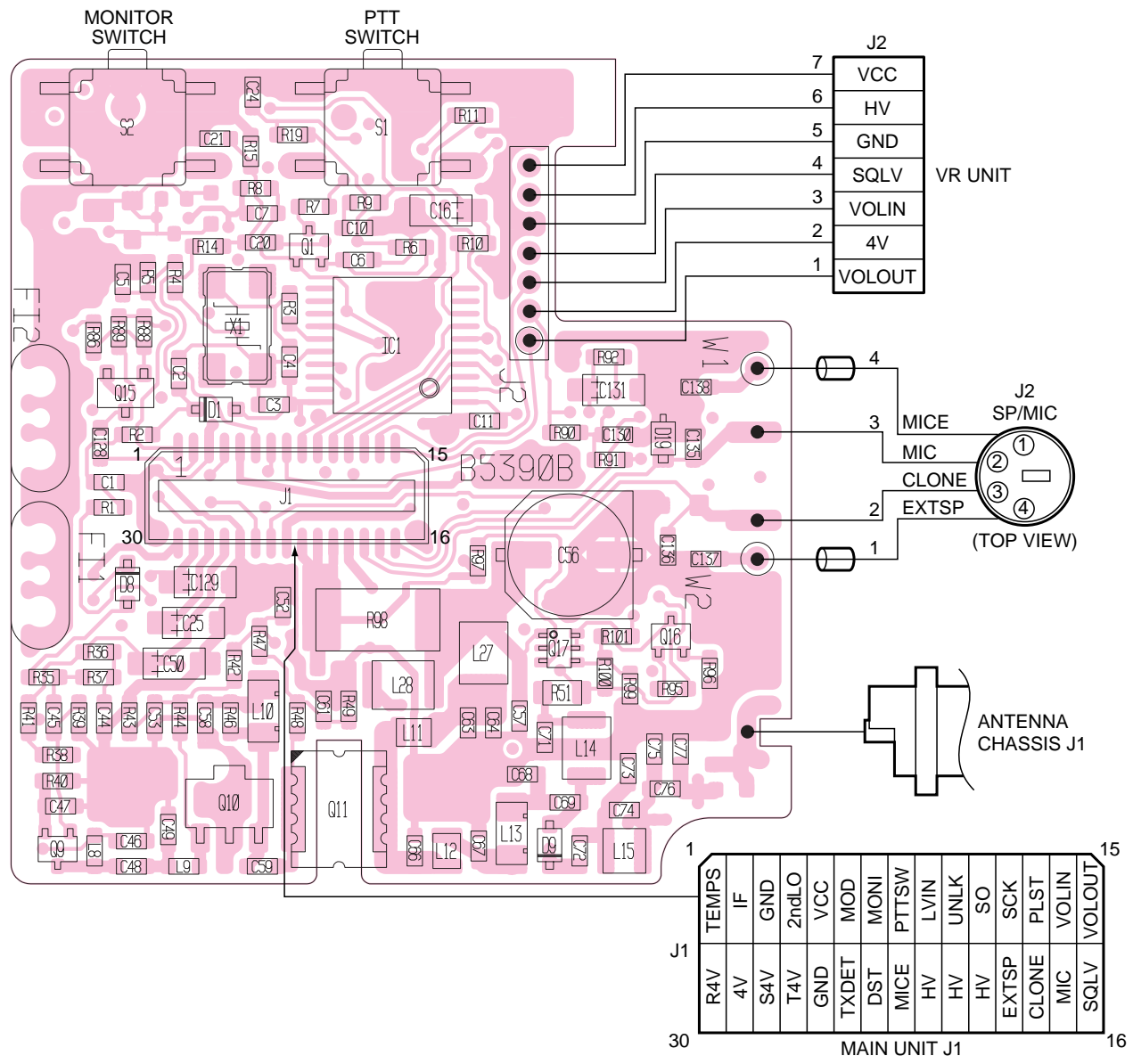

RF UNIT IC-M1EURO V

• BOTTOM VIEW

The combination of this page and the previous page shows the unit layout in the same configuration as the actual P.C. Board.

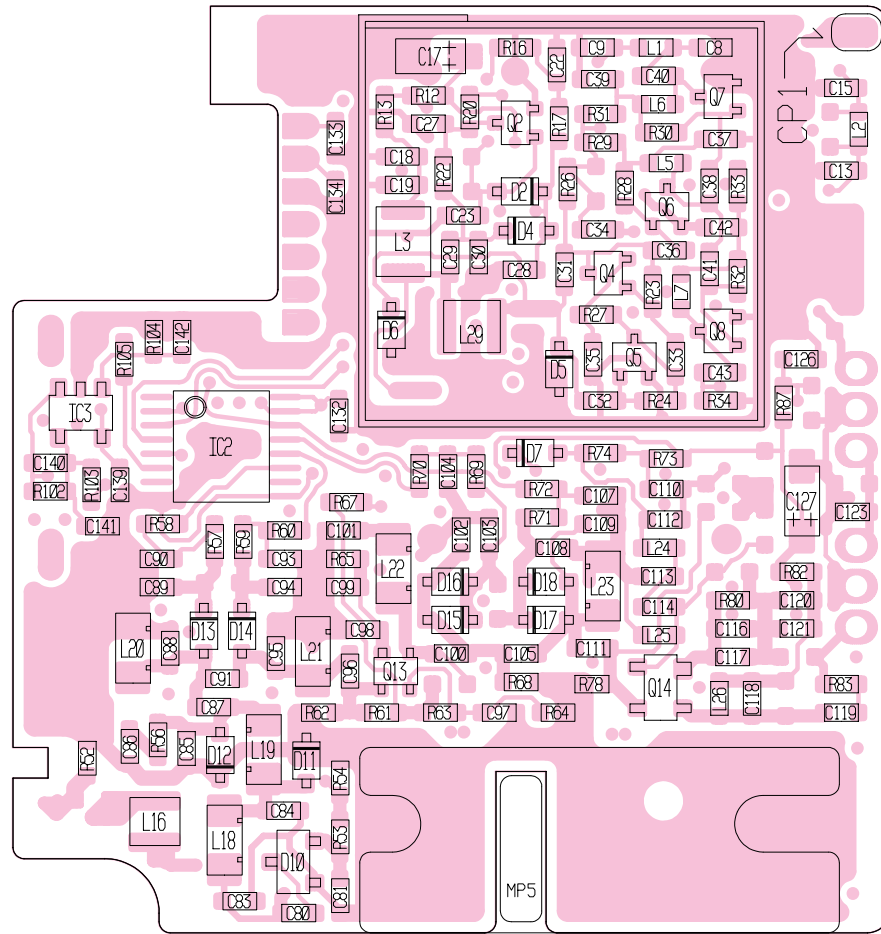

RF UNIT IC-M1V

• BOTTOM VIEW

The combination of this page and the previous page shows the unit layout in the same configuration as the actual P.C. Board.

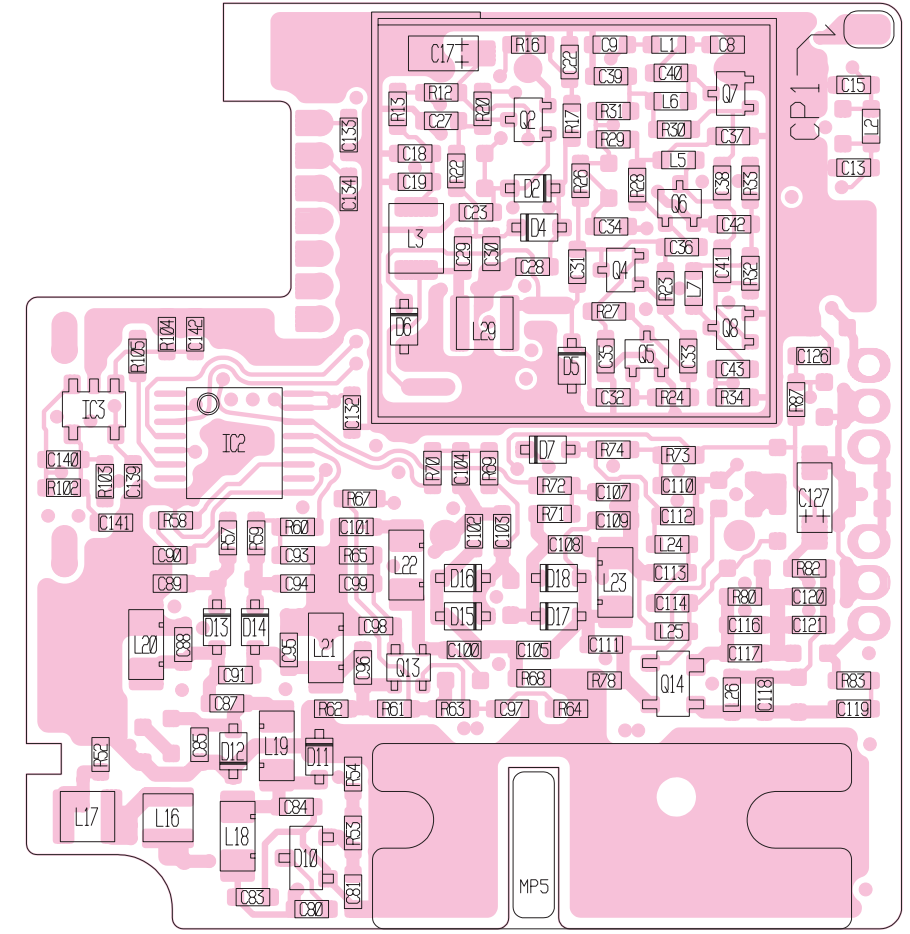

VR UNIT

• BOTTOM VIEW

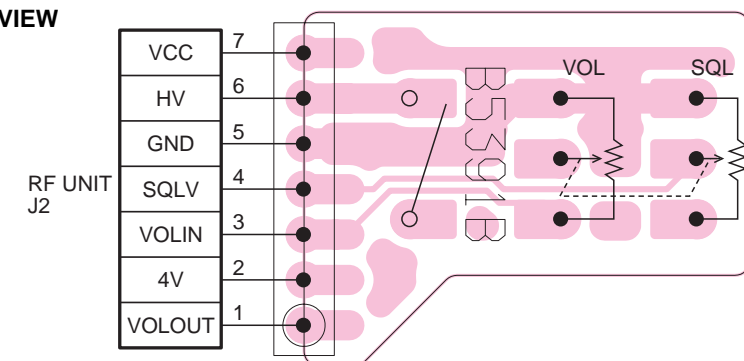

9 - 3 MAIN UNIT

• TOP VIEW

The combination of this page and the next page shows the unit layout in the same configuration as the actual P.C. Board.

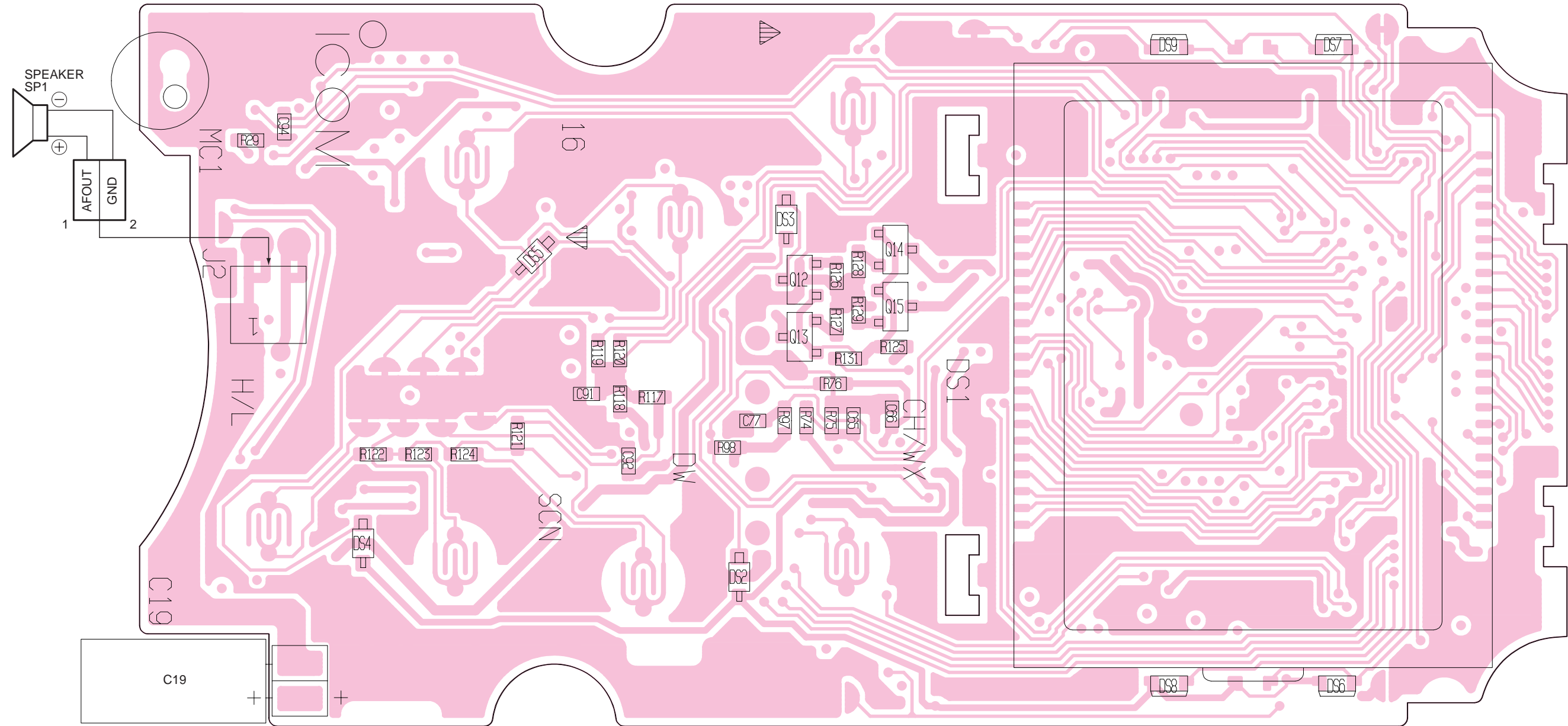

• BOTTOM VIEW

The combination of this page and the previous page shows the unit layout in the same configuration as the actual P.C. Board.

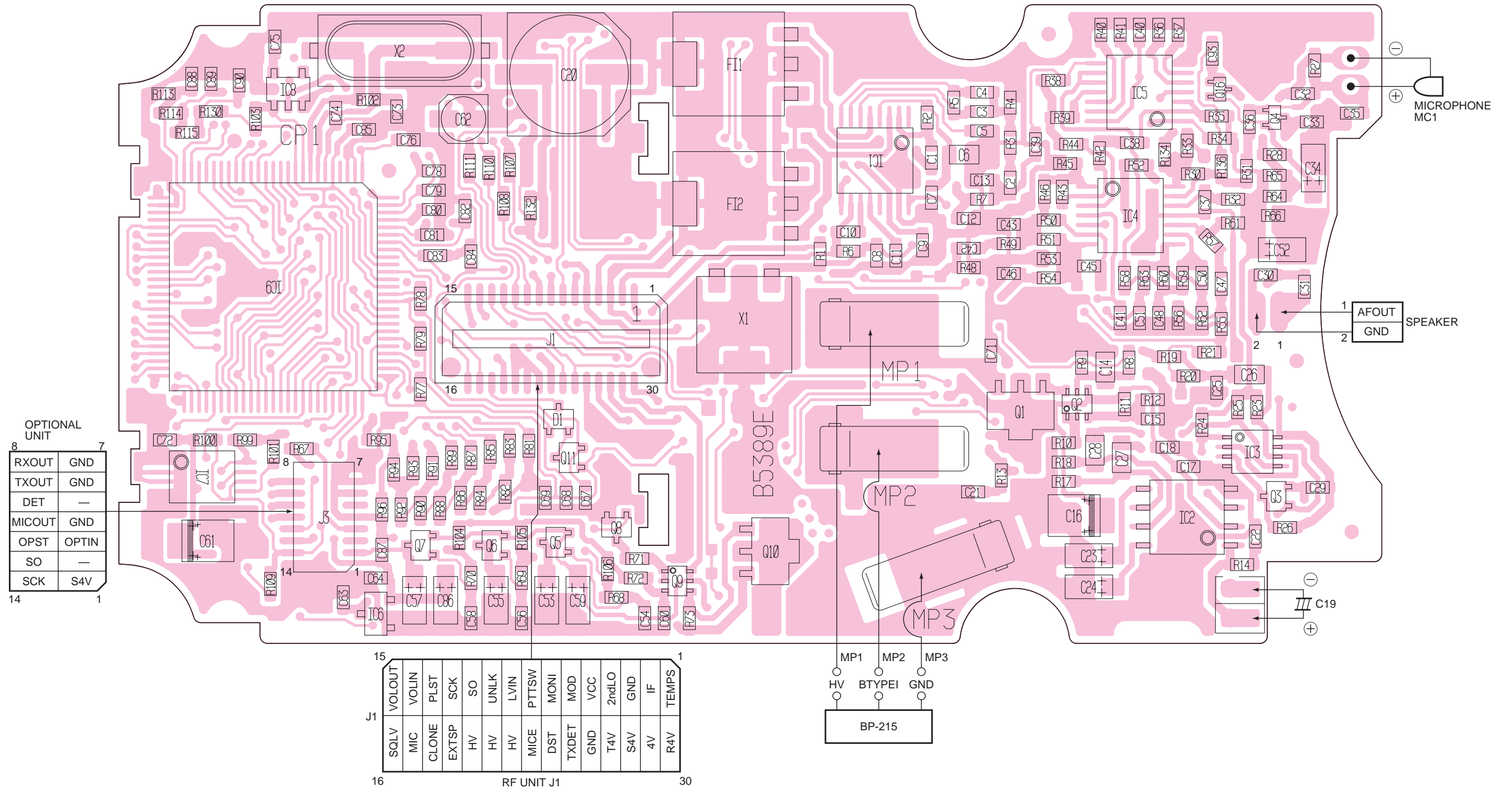

OPTIONAL UNIT

8	RXOUT	GND	7
	TXOUT	GND	
	DET	—	
	MICOUT	GND	
	OPST	OPTIN	
	SO	—	
14	SCK	S4V	1

15	SQLV	VOLOUT	1
	MIC	VOLIN	
	CLONE	PLST	
	EXTSP	SCK	
	HV	SO	
	HV	UNLK	
	HV	LVIN	
	MICE	PTTSW	
	DST	MONI	
	TXDET	MOD	
	GND	VCC	
	T4V	2ndLO	
	S4V	GND	
	4V	IF	
16	R4V	TEMPS	30

RF UNIT J1

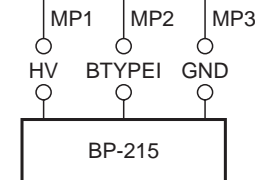

SECTION 10 BLOCK DIAGRAM

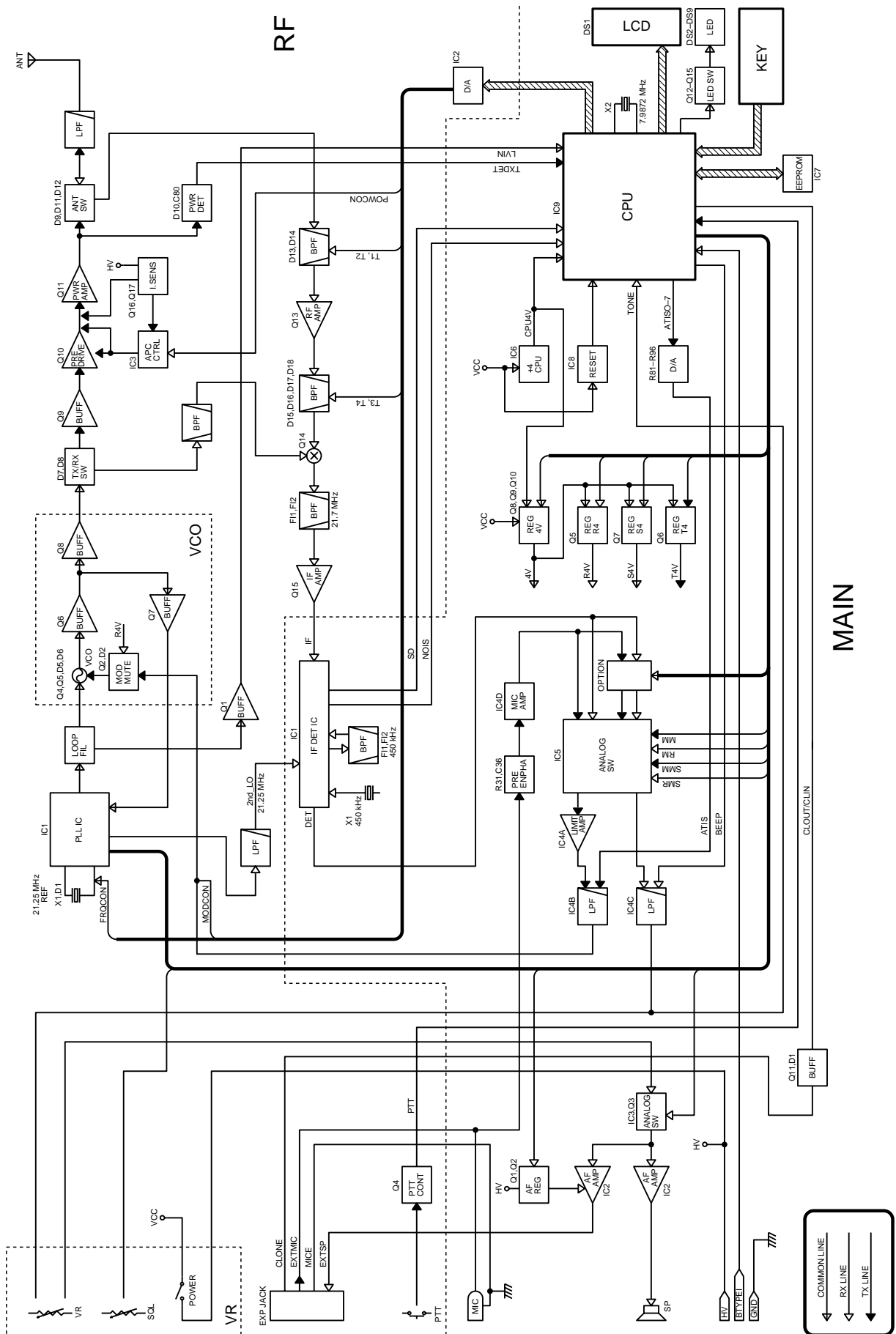

SECTION 11 VOLTAGE DIAGRAM

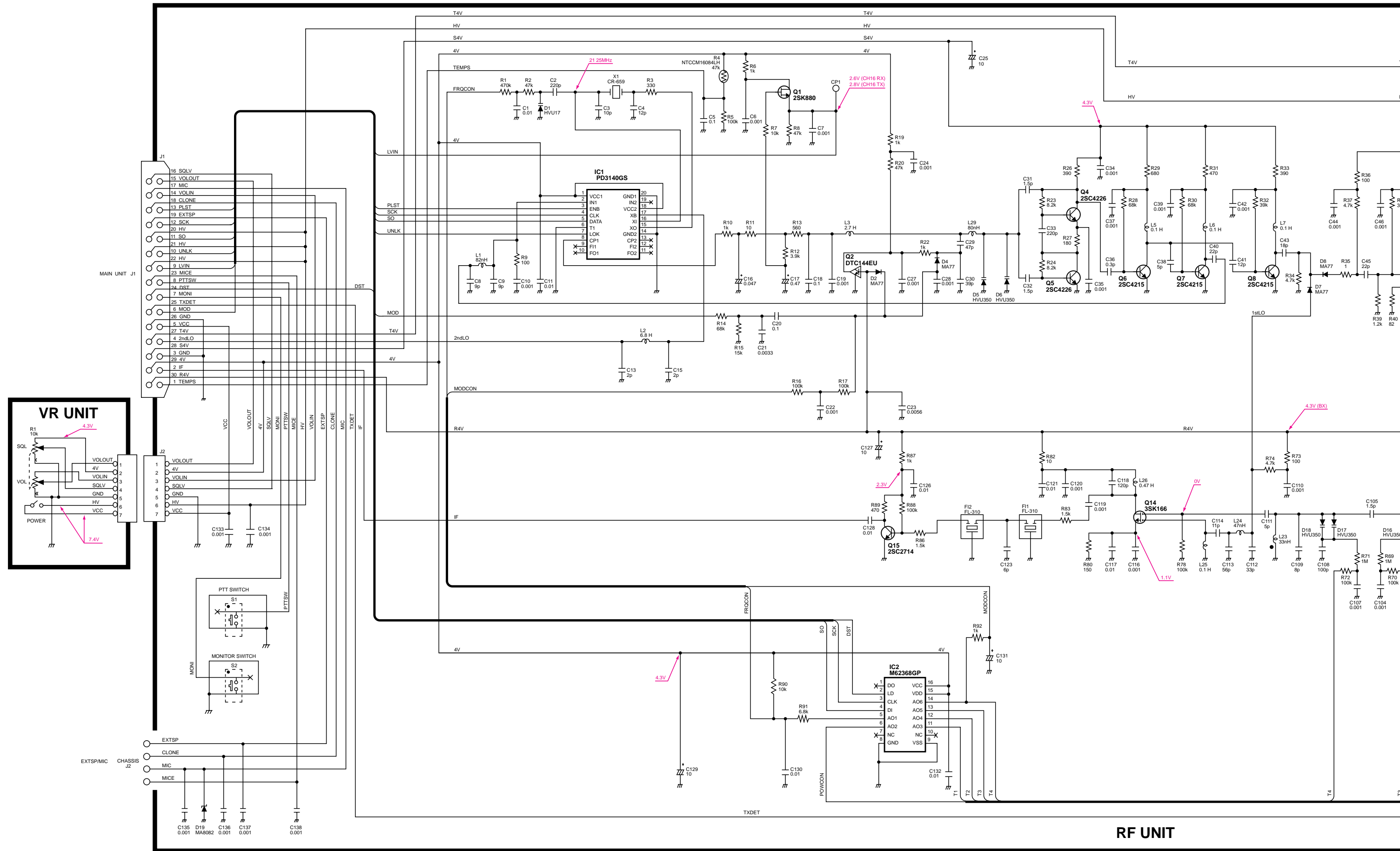

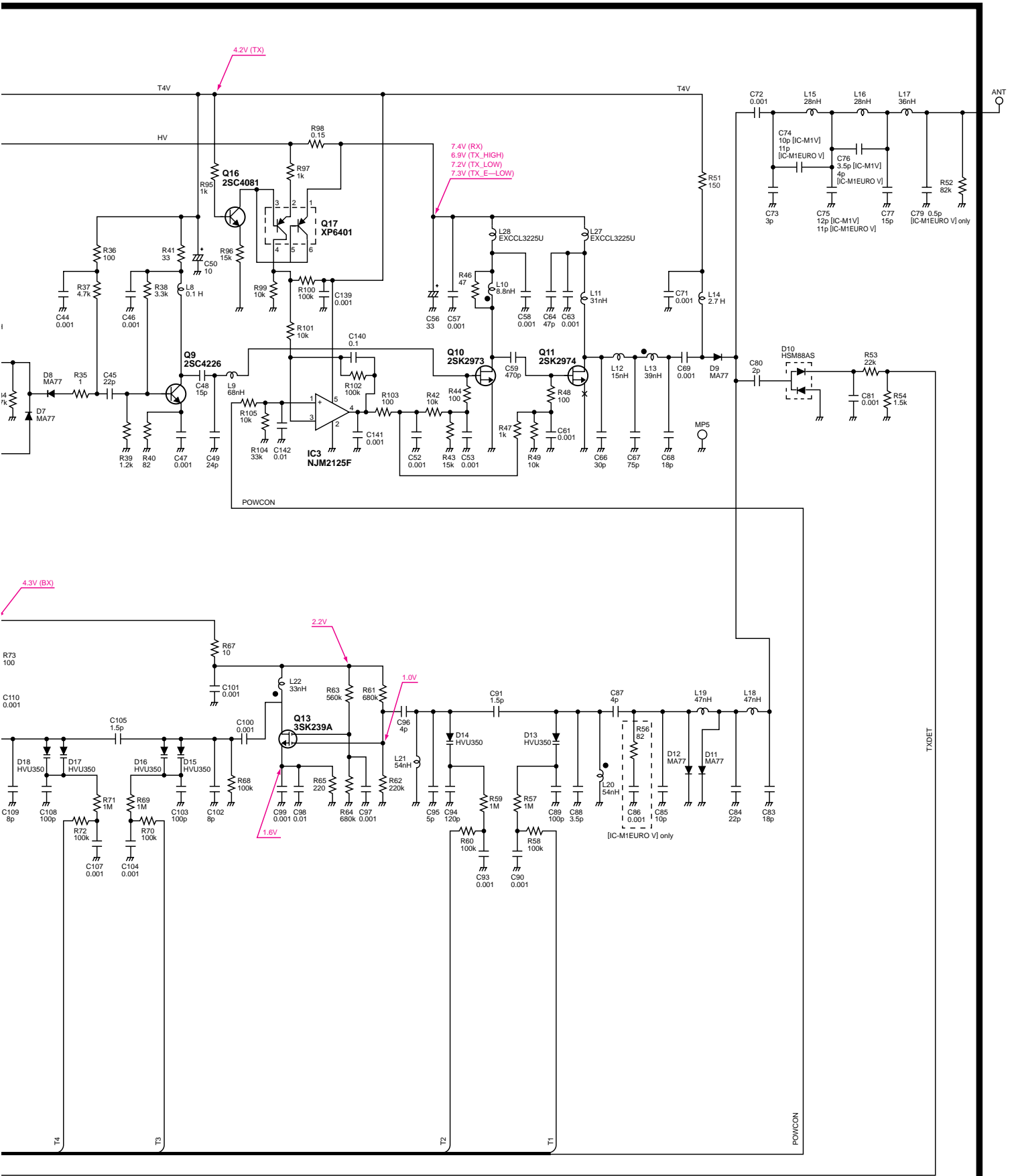

COMPLETE VIEW

SECTION 11 VOLTAGE DIAGRAM

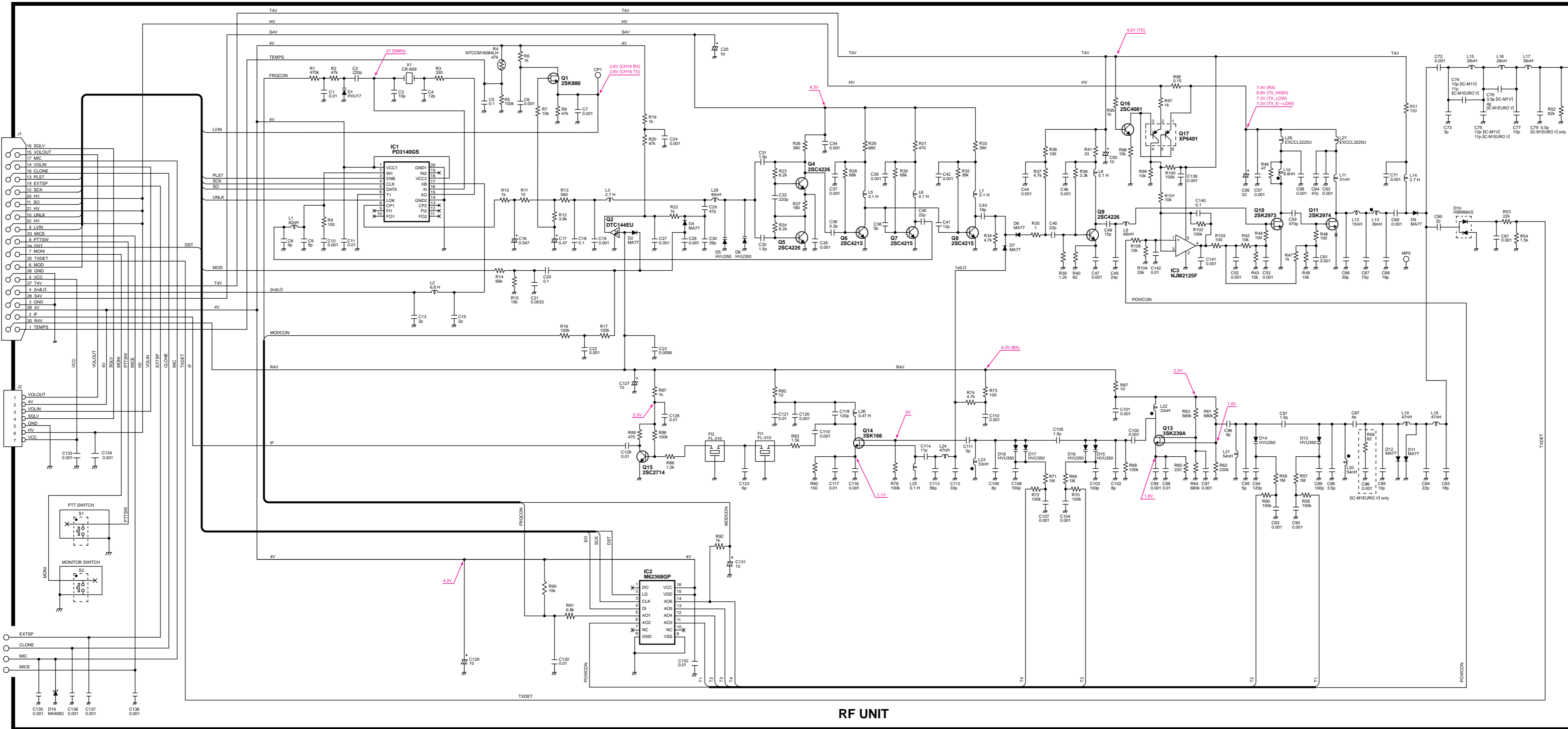
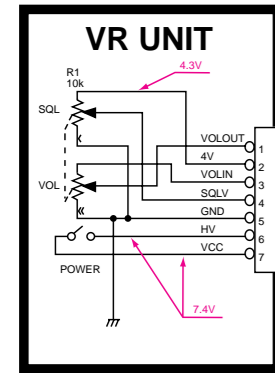

RF UNIT

LEFT SIDE

RIGHT SIDE

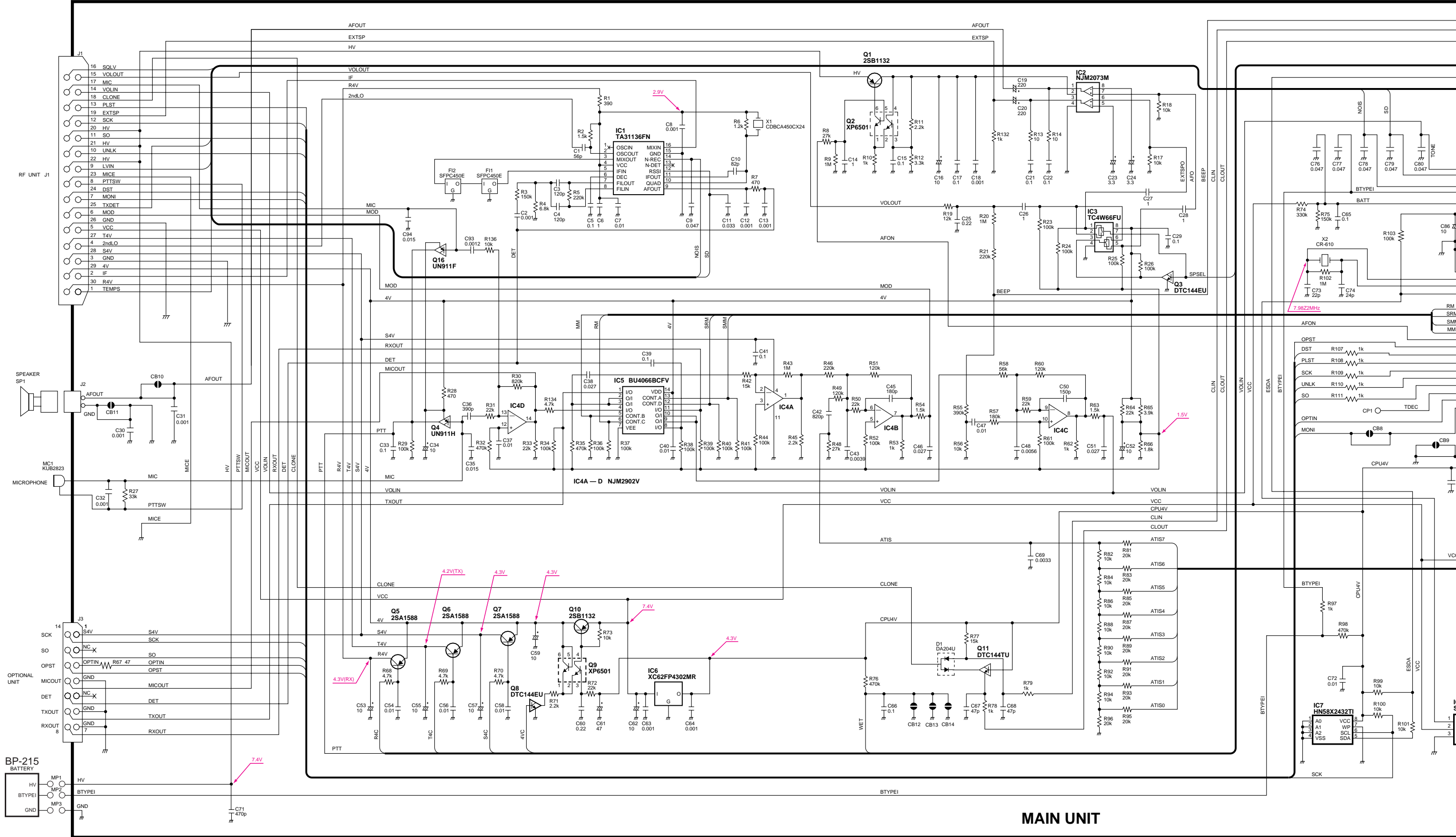

MAIN UNIT



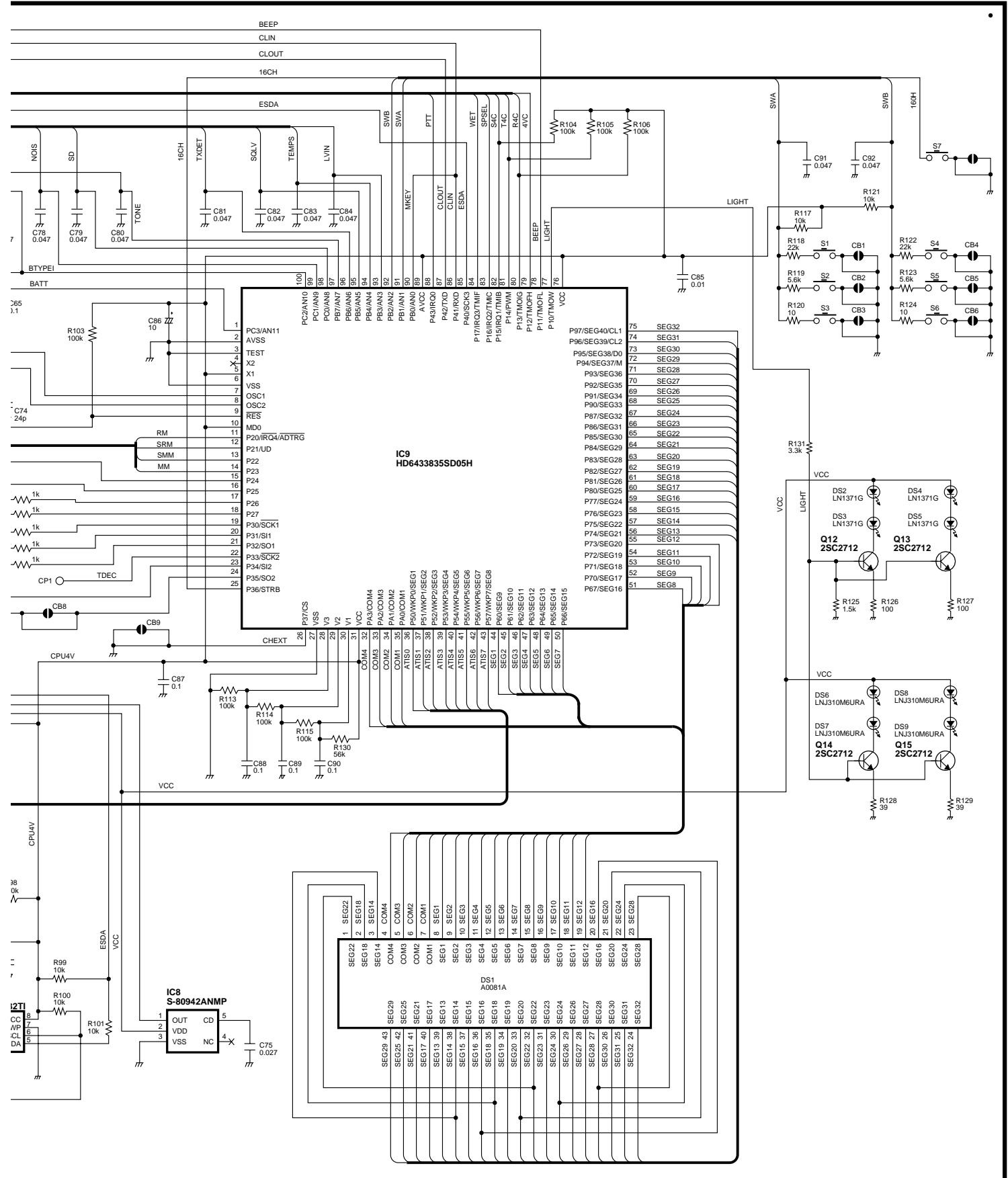

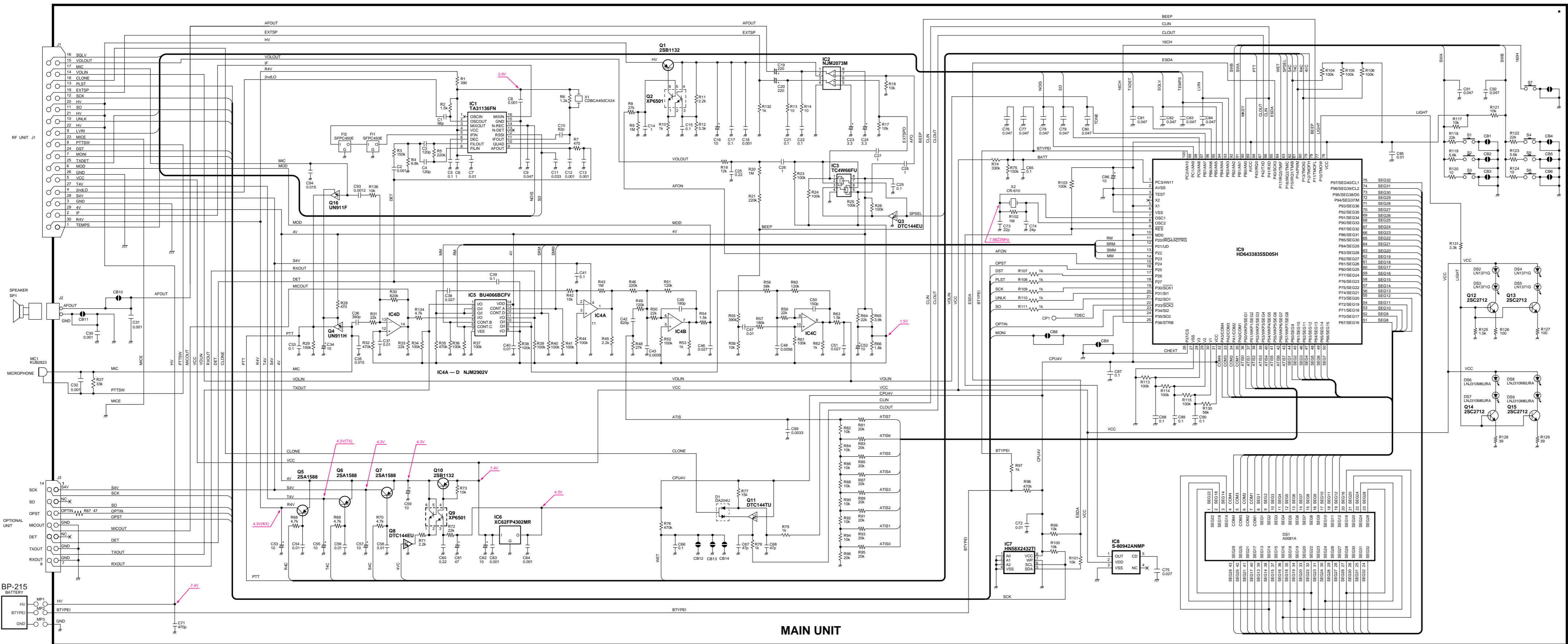

Count on us!